



Horizontal Single Stage- Single Suction Pump

50Hz DSV SERIES



SHANGHAI SINO-KOREA DOOCH PUMP MFG CO., LTD.

NO.239 ZhangLiantang Road, Liantang Industrial Park, Qingpu District, Shanghai City, China.
Tel: +86.21.67679390-224 Fax: +86.21.67679396



SHANGHAI SINO-KOREA DOOCH PUMP MFG CO., LTD.



Introduction

The DSV series centrifugal pump is a new generation of single-pole single-suction centrifugal pump with high efficiency, long service life and low repair rate. Its excellent hydraulic model and structural features ensure that the user can effectively reduce the operating cost of the pump. It is mainly used in water supply, industrial pressurization, industrial liquid transfer, heating, ventilation and air conditioning, and irrigation.

Model Meaning

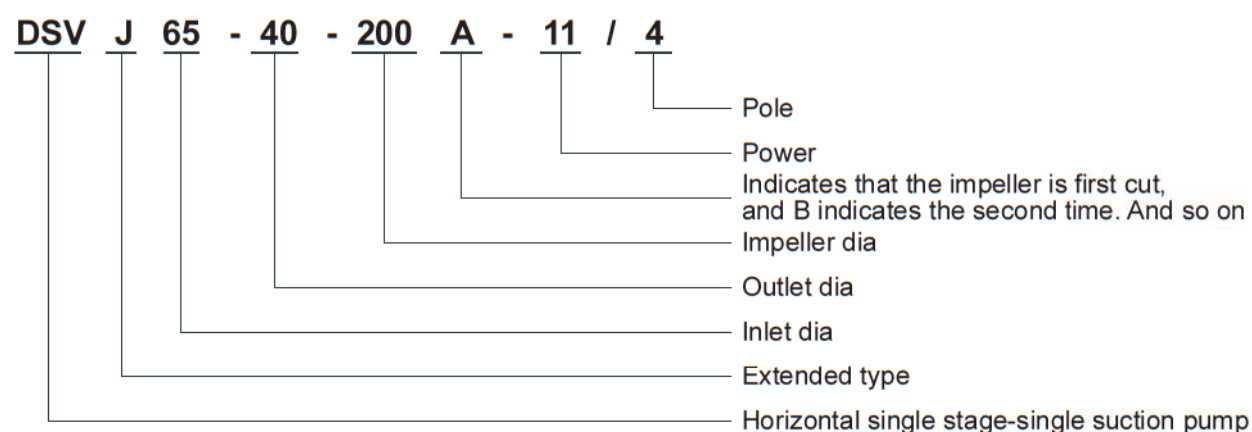

Technical Parameter

Inlet dia: DN50~DN300
 Outlet dia: DN32~DN250
 Max. Flow: 1300m³/h
 Max. Head: 250m
 Medium Temperature: 0~110°C

Product Features

- non-self-priming, with axial suction, radial discharge structure;
- Comply with ISO258 international standards, interchangeable with other products that meet the requirements of the standard;
- The pump cover adopts a rear open structure. The rotor part can be removed from the drive end without removing the pump body from the pipeline;
- A wide range of performance, high efficiency;
- Longer structure, when replacing the impeller and machine seal, no need to disassemble the pump body and motor;
- Low noise, low vibration and reliable operation.

Applied Range

- Deliver clean, non-corrosive liquids free of solid particles and fibers;
 - The medium corrosive medium can be transported as for the flow component is stainless steel; Water supply, distribution and pressurization of the water supply system;
 - Artificial landscape water supply boost, plantation irrigation, etc.;
 - Circulating water supply, cooling water transportation, boiler feeding water, industrial water supply and drainage, etc.
- Industrial process systems; Water supply, fire water supply, air conditioning circulating water transportation for high-rise buildings used in the construction industry

Structure Diagram

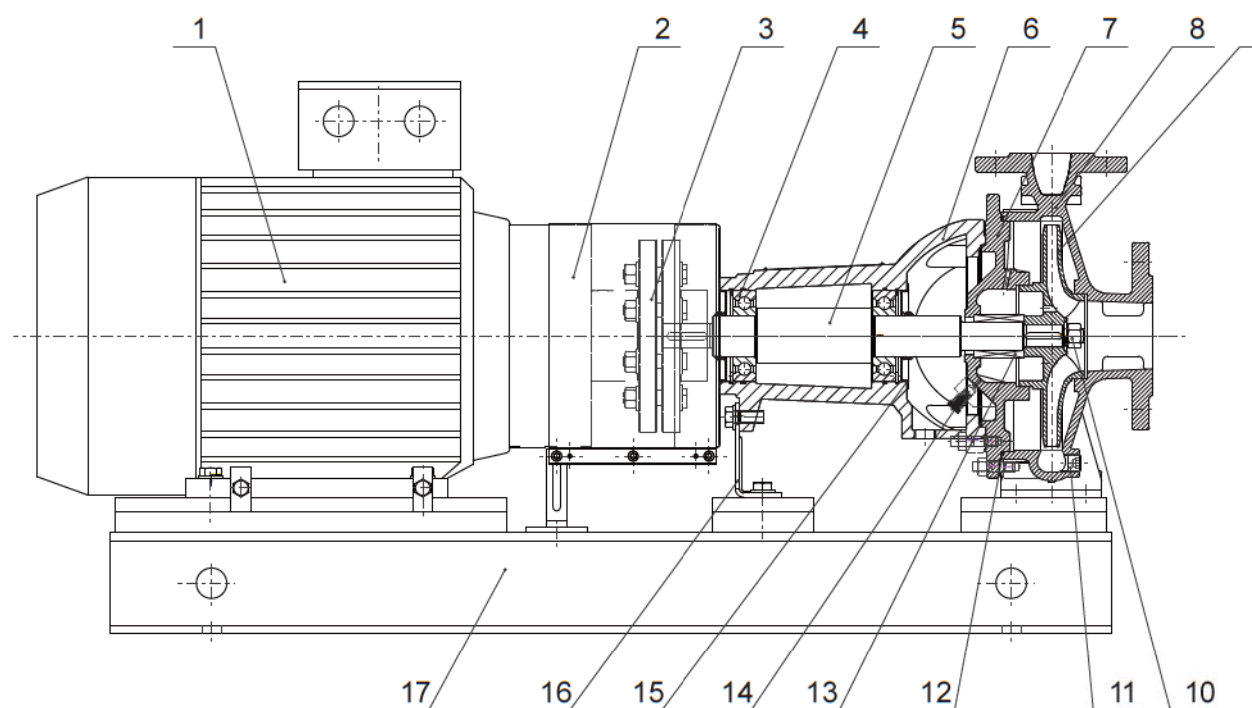

S/N	Components Part	Material	S/N	Components Part	Material
1	Motor		10	Impeller Nut	06Cr19Ni10
2	Coupling Cover	Q235-A	11	Water Release Cock	06Cr19Ni10
3	Coupling	45	12	O-ring	NBR
4	Bearing		13	Mechanical Seal	SiC / Graphite
5	Shaft	20Cr13	14	Bleed Cock	06Cr19Ni10
6	Suspension Bracket	HT250	15	Bearing Cover	06Cr19Ni10
7	Pump Cover	HT250	16	Bracket	Q235-A
8	Pump Body	HT250	17	Base	Q235-A
9	Impeller	HT250/06Cr19Ni10			

Type Diagram

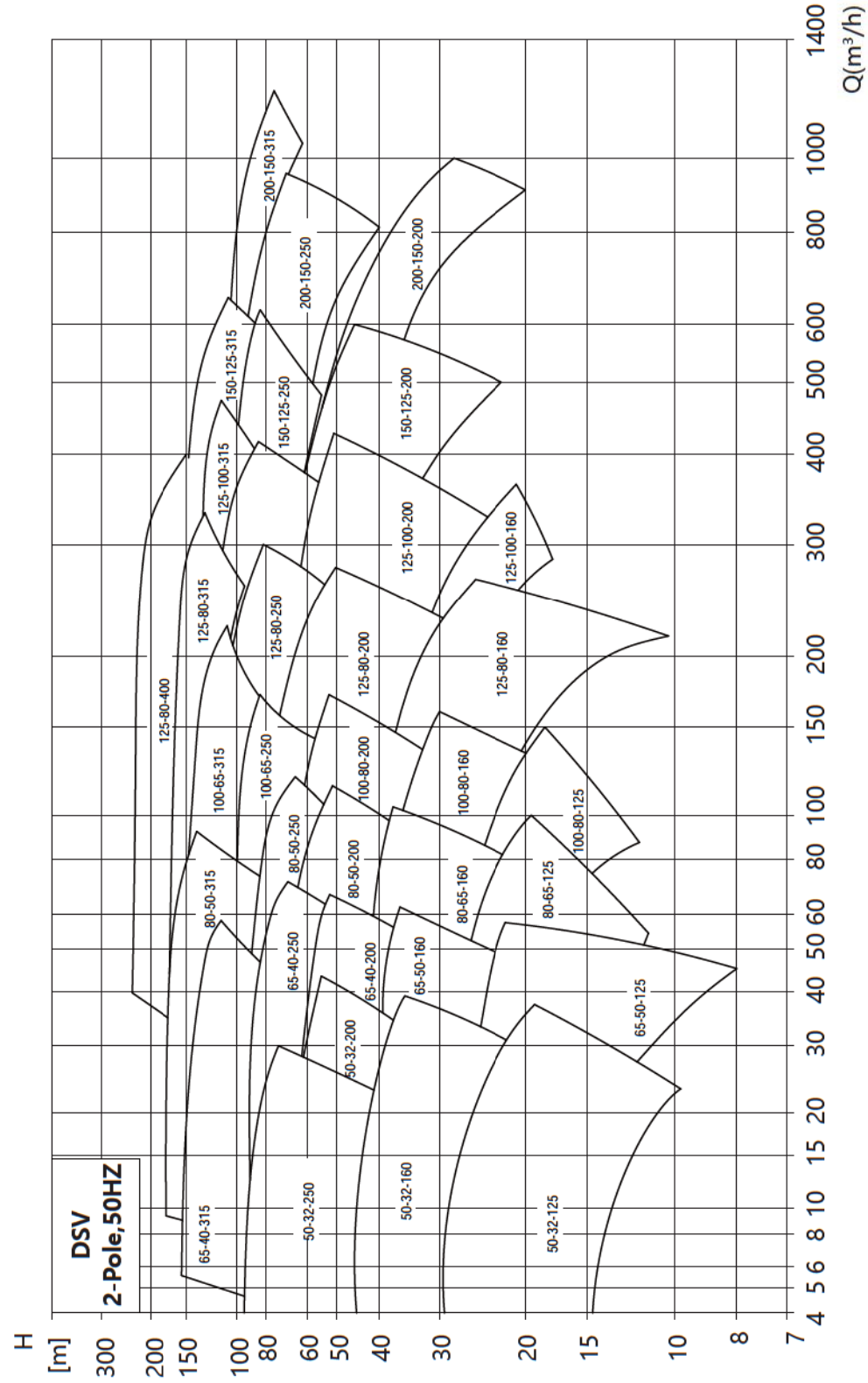

Type Diagram

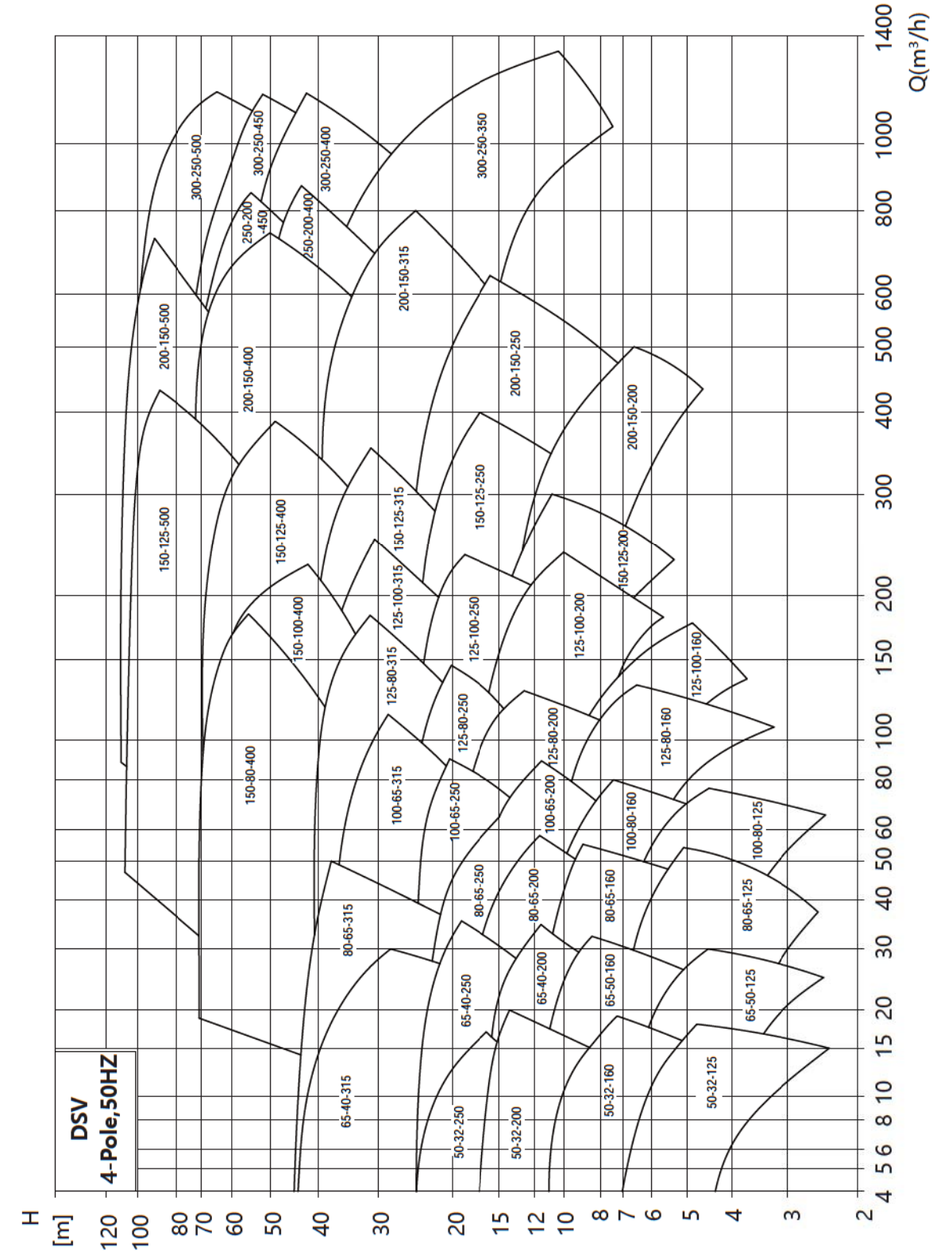

Installation Data

TYPE A

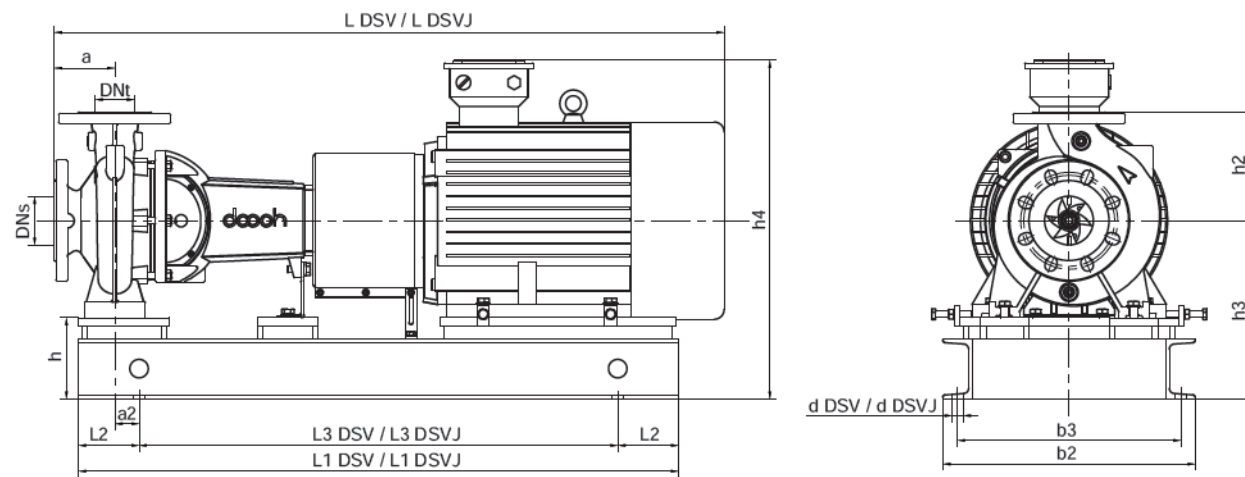

TYPE C

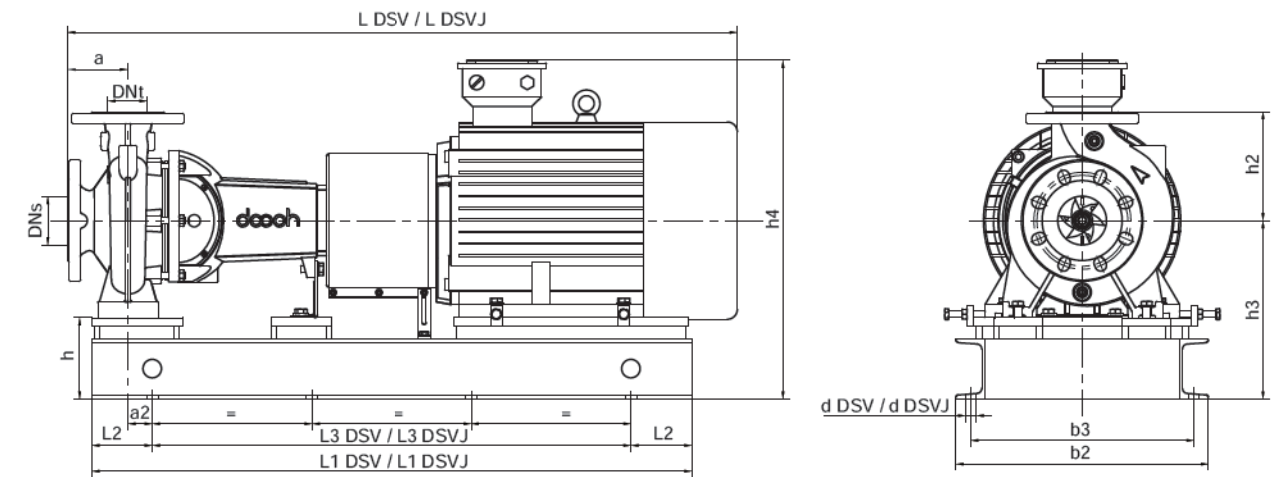

TYPE B

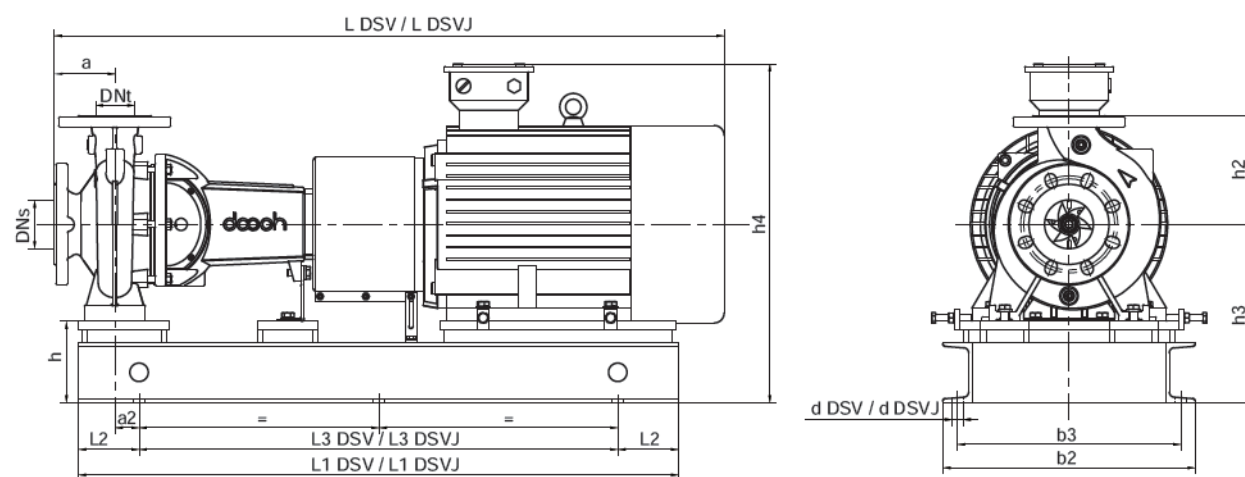

Installation Data

Model	Power/ Pole	Motor Model	DNs	DNt	L2	b2	b3	a	a2	h	h2	h3	h4	L DSV	L1 DSV	L3 DSV	d DSV	L DSVJ	L1 DSVJ	L3 DSVJ	d DSVJ	DSV Weight (kg)	DSVJ Weight (kg)	DSV/ DSVJType
50-32-125	1.1/2	YE2-80M2-2	50	32	100	312	277	80	40	93	140	205	345	755	710	510	4-Φ14	890	845	645	4-Φ14	94	97	TypeA/TypeA
	1.5/2	YE2-90S-2	50	32	100	312	277	80	40	93	140	205	360	790	710	510	4-Φ14	925	845	645	4-Φ14	95	98	TypeA/TypeA
	2.2/2	YE2-90L-2	50	32	100	312	277	80	40	93	140	205	360	815	710	510	4-Φ14	950	845	645	4-Φ14	98	101	TypeA/TypeA
	3/2	YE2-100L-2	50	32	100	346	303	80	40	130	140	242	407	855	750	550	4-Φ19	990	900	700	4-Φ19	124	128	TypeA/TypeA
	0.25/4	YE2-71M1-4	50	32	100	330	295	80	40	93	140	205	/	720	645	445	4-Φ14	855	780	580	4-Φ14	89	92	TypeA/TypeA
	0.25/4	YE2-71M1-4	50	32	100	330	295	80	40	93	140	205	/	720	645	445	4-Φ14	855	780	580	4-Φ14	89	92	TypeA/TypeA
	0.37/4	YE2-71M2-4	50	32	100	330	295	80	40	93	140	205	/	720	645	445	4-Φ14	855	780	580	4-Φ14	89	92	TypeA/TypeA

Model	Power/ Pole	Motor Model	DNs	DNt	L2	b2	b3	a	a2	h	h2	h3	h4	L DSV	L1 DSV	L3 DSV	d DSV	L DSVJ	L1 DSVJ	L3 DSVJ	d DSVJ	DSV Weight (kg)	DSVJ Weight (kg)	DSV/ DSVJType
50-32-160	2.2/2	YE2-90L-2	50	32	100	312	277	80	40	73	160	205	360	815	710	510	4-Φ14	950	845	645	4-Φ14	101	104	TypeA/TypeA
	3/2	YE2-100L-2	50	32	100	346	303	80	40	110	160	242	407	855	750	550	4-Φ19	990	900	700	4-Φ19	123	127	TypeA/TypeA
	4/2	YE2-112M-2	50	32	100	346	303	80	40	114	160	246	434	865	765	565	4-Φ19	1000	903	703	4-Φ19	136	140	TypeA/TypeA
	5.5/2	YE2-132S1-2	50	32	100	341	298	80	40	114	160	246	449	940	850	650	4-Φ19	1075	927	727	4-Φ19	161	163	TypeA/TypeA
	0.25/4	YE2-71M1-4	50	32	100	330	295	80	40	73	160	205	/	720	645	445	4-Φ14	855	780	580	4-Φ14	89	92	TypeA/TypeA
	0.37/4	YE2-71M2-4	50	32	100	330	295	80	40	73	160	205	/	720	645	445	4-Φ14	855	780	580	4-Φ14	90	93	TypeA/TypeA
	0.55/4	YE2-80M1-4	50	32	100	300	265	80	40	73	160	205	345	755	700	500	4-Φ14	890	835	635	4-Φ14	96	99	TypeA/TypeA
	0.75/4	YE2-80M2-4	50	32	100	300	265	80	40	73	160	205	345	755	700	500	4-Φ14	890	835	635	4-Φ14	97	100	TypeA/TypeA

Model	Power/ Pole	Motor Model	DNs	DNt	L2	b2	b3	a	a2	h	h2	h3	h4	L DSV	L1 DSV	L3 DSV	d DSV	L DSVJ	L1 DSVJ	L3 DSVJ	d DSVJ	DSV Weight (kg)	DSVJ Weight (kg)	DSV/ DSVJType
50-32-200	4/2	YE2-112M-2	50	32	100	346	303	80	40	114	180	274	462	865	765	565	4-Φ19	1000	903	703	4-Φ19	150	154	TypeA/TypeA
	5.5/2	YE2-132S1-2	50	32	100	341	298	80	40	114	180	274	477	940	850	650	4-Φ19	1075	927	727	4-Φ19	174	176	TypeA/TypeA
	7.5/2	YE2-132S2-2	50	32	100	341	298	80	40	114	180	274	477	940	850	650	4-Φ19	1075	927	727	4-Φ19	181	183	TypeA/TypeA
	11/2	YE2-160M1-2	50	32	100	416	373	80	40	134	180	294	545	1082	990	790	4-Φ19	1217	1126	926	6-Φ19	241	245	TypeA/TypeB
	0.55/4	YE2-80M1-4	50	32	100	400	365	80	40	97	180	257	397	755	685	485	4-Φ14	890	820	620	4-Φ14	113	116	TypeA/TypeA
	0.75/4	YE2-80M2-4	50	32	100	400	365	80	40	97	180	257	397	755	685	485	4-Φ14	890	820	620	4-Φ14	115	118	TypeA/TypeA
	1.1/4	YE2-90S-4	50	32	100	400	365	80	40	97	180	257	412	790	730	530	4-Φ14	925	884	684	4-Φ14	123	126	TypeA/TypeA
	1.5/4	YE2-90L-4	50	32	100	400	365	80	40	97	180	257	412	815	730	530	4-Φ14	950	884	684	4-Φ14	127	130	TypeA/TypeA

Installation Data

Model	Power/ Pole	Motor Model	DNs	DNt	L2	b2	b3	a	a2	h	h2	h3	h4	L DSV	L1 DSV	L3 DSV	d DSV	L DSVJ	L1 DSVJ	L3 DSVJ	d DSVJ	DSV Weight (kg)	DSVJ Weight (kg)	DSV/ DSVJType
50-32-250	5.5/2	YE2-132S1-2	50	32	100	446	403	100	25	114	225	294	497	1075	980	780	4-Φ19	1270	1176	976	6-Φ19	209	215	TypeA/TypeB
	7.5/2	YE2-132S2-2	50	32	100	446	403	100	25	114	225	294	497	1075	980	780	4-Φ19	1270	1176	976	6-Φ19	216	222	TypeA/TypeB
	11/2	YE2-160M1-2	50	32	100	446	403	100	25	114	225	294	545	1217	1140	940	6-Φ19	1412	1330	1130	6-Φ19	270	276	TypeB/TypeB
	15/2	YE2-160M2-2	50	32	100	446	403	100	25	114	225	294	545	1217	1140	940	6-Φ19	1412	1330	1130	6-Φ19	301	307	TypeB/TypeB
	0.75/4	YE2-80M2-4	50	32	100	400	365	100	25	77	225	257	397	890	805	605	4-Φ14	1085	1000	800	6-Φ14	139	145	TypeA/TypeB
	1.1/4	YE2-90S-4	50	32	100	400	365	100	25	77	225	257	412	925	840	640	4-Φ14	1120	1036	836	6-Φ14	149	155	TypeA/TypeB
	1.5/4	YE2-90L-4	50	32	100	400	365	100	25	77	225	257	412	950	840	640	4-Φ14	1145	1036	836	6-Φ14	153	159	TypeA/TypeB
	2.2/4	YE2-100L1-4	50	32	100	416	373	100	25	114	225	294	459	990	900	700	4-Φ19	1185	1096	896	6-Φ19	176	182	TypeA/TypeB

Model	Power/ Pole	Motor Model	DNs	DNt	L2	b2	b3	a	a2	h	h2	h3	h4	L DSV	L1 DSV	L3 DSV	d DSV	L DSVJ	L1 DSVJ	L3 DSVJ	d DSVJ	DSV Weight (kg)	DSVJ Weight (kg)	DSV/ DSVJType
65-50-125	1.5/2	YE2-90S-2	65	50	100	312	277	80	40	93	140	205	360	790	710	510	4-Φ14	925	845	645	4-Φ14	99	102	TypeA/TypeA
	2.2/2	YE2-90L-2	65	50	100	312	277	80	40	93	140	205	360	815	710	510	4-Φ14	950	845	645	4-Φ14	103	106	TypeA/TypeA
	3/2	YE2-100L-2	65	50	100	346	303	80	40	130	140	242	407	855	750	550	4-Φ19	990	900	700	4-Φ19	130	134	TypeA/TypeA
	4/2	YE2-112M-2	65	50	100	346	303	80	40	134	140	246	434	865	765	565	4-Φ19	1000	903	703	4-Φ19	141	145	TypeA/TypeA
	5.5/2	YE2-132S1-2	65	50	100	341	298	80	40	134	140	246	449	940	850	650	4-Φ19	1075	927	727	4-Φ19	168	172	TypeA/TypeA
	0.25/4	YE2-71M1-4	65	50	100	330	295	80	40	93	140	205	/	720	645	445	4-Φ14	855	780	580	4-Φ14	92	95	TypeA/TypeA
	0.37/4	YE2-71M2-4	65	50	100	330	295	80	40	93	140	205	/	720	645	445	4-Φ14	855	780	580	4-Φ14	93	96	TypeA/TypeA
	0.55/4	YE2-80M1-4	65	50	100	312	277	80	40	93	140	205	345	755	710	510	4-Φ14	890	845	645	4-Φ14	96	99	TypeA/TypeA

Model	Power/ Pole	Motor Model	DNs	DNt	L2	b2	b3	a	a2	h	h2	h3	h4	L DSV	L1 DSV	L3 DSV	d DSV	L DSVJ	L1 DSVJ	L3 DSVJ	d DSVJ	DSV Weight (kg)	DSVJ Weight (kg)	DSV/ DSVJType
65-50-160	4/2	YE2-112M-2	65	50	100	346	303	80	40	114	160	246	434	865	765	565	4-Φ19	1000	903	703	4-Φ19	140	144	TypeA/TypeA
	5.5/2	YE2-132S1-2	65	50	100	341	298	80	40	114	160	246	449	940	850	650	4-Φ19	1075	927	727	4-Φ19	166	168	TypeA/TypeA
	7.5/2	YE2-132S2-2	65	50	100	341	298	80	40	114	160	246	449	940	850	650	4-Φ19	1075	927	727	4-Φ19	173	175	TypeA/TypeA
	11/2	YE2-160M1-2	65	50	100	416	373	80	40	142	160	274	525	1082	990	790	4-Φ19	1217	1130	930	6-Φ19	224	228	TypeA/TypeB
	0.37/4	YE2-71M2-4	65	50	100	330	295	80	40	73	140	205	/	720	645	445	4-Φ14	855	780	580	4-Φ14	94	97	TypeA/TypeA
	0.55/																							

Installation Data

Model	Power/ Pole	Motor Model	DNs	DNt	L2	b2	b3	a	a2	h	h2	h3	h4	L DSV	L1 DSV	L3 DSV	d DSV	L DSVJ	L1 DSVJ	L3 DSVJ	d DSVJ	DSV Weight (kg)	DSVJ Weight (kg)	DSV/ DSVJType
65-40-200	5.5/2	YE2-132S1-2	65	40	100	341	298	100	40	114	180	274	477	960	850	650	4-Φ19	1095	927	727	4-Φ19	175	177	TypeA/TypeA
	7.5/2	YE2-132S2-2	65	40	100	341	298	100	40	114	180	274	477	960	850	650	4-Φ19	1095	927	727	4-Φ19	182	184	TypeA/TypeA
	11/2	YE2-160M1-2	65	40	100	416	373	100	40	134	180	294	545	1102	990	790	4-Φ19	1237	1112	912	6-Φ19	242	246	TypeA/TypeB
	15/2	YE2-160M2-2	65	40	100	416	373	100	40	134	180	294	545	1102	990	790	4-Φ19	1237	1112	912	6-Φ19	256	260	TypeA/TypeB
	0.75/4	YE2-80M2-4	65	40	100	400	365	100	40	97	180	257	397	775	685	485	4-Φ14	910	820	620	4-Φ14	116	119	TypeA/TypeA
	1.1/4	YE2-90S-4	65	40	100	400	365	100	40	97	180	257	412	810	730	530	4-Φ14	945	884	684	4-Φ14	124	127	TypeA/TypeA
	1.5/4	YE2-90L-4	65	40	100	400	365	100	40	97	180	257	412	835	730	530	4-Φ14	970	884	684	4-Φ14	128	131	TypeA/TypeA
	2.2/4	YE2-100L1-4	65	40	100	346	303	100	40	114	140	274	439	875	750	550	4-Φ19	1010	900	700	4-Φ19	130	134	TypeA/TypeA

Model	Power/ Pole	Motor Model	DNs	DNt	L2	b2	b3	a	a2	h	h2	h3	h4	L DSV	L1 DSV	L3 DSV	d DSV	L DSVJ	L1 DSVJ	L3 DSVJ	d DSVJ	DSV Weight (kg)	DSVJ Weight (kg)	DSV/ DSVJType
65-40-250	11/2	YE2-160M1-2	65	40	100	446	403	100	25	114	225	294	545	1217	1140	940	6-Φ19	1412	1330	1130	6-Φ19	269	275	TypeB/TypeB
	15/2	YE2-160M2-2	65	40	100	446	403	100	25	114	225	294	545	1217	1140	940	6-Φ19	1412	1330	1130	6-Φ19	283	289	TypeB/TypeB
	18.5/2	YE2-160L-2	65	40	100	446	403	100	25	114	225	294	545	1261	1140	940	6-Φ19	1456	1330	1130	6-Φ19	305	311	TypeB/TypeB
	22/2	YE2-180M-2	65	40	100	470	418	100	25	154	225	334	614	1300	1150	950	6-Φ24	1495	1344	1144	6-Φ24	368	374	TypeB/TypeB
	30/2	YE2-200L1-2	65	40	100	480	428	100	25	172	225	352	662	1385	1225	1025	6-Φ24	1580	1420	1220	6-Φ24	423	429	TypeB/TypeB
	1.5/4	YE2-90L-4	65	40	100	400	365	100	25	77	225	257	412	950	840	640	4-Φ14	1145	1036	836	6-Φ14	151	157	TypeA/TypeB
	2.2/4	YE2-100L1-4	65	40	100	416	373	100	25	114	225	294	459	990	900	700	4-Φ19	1185	1096	896	6-Φ19	174	180	TypeA/TypeB
	3/4	YE2-100L2-4	65	40	100	416	373	100	25	114	225	294	459	990	900	700	4-Φ19	1185	1096	896	6-Φ19	182	188	TypeA/TypeB

Model	Power/ Pole	Motor Model	DNs	DNt	L2	b2	b3	a	a2	h	h2	h3	h4	L DSV	L1 DSV	L3 DSV	d DSV	L DSVJ	L1 DSVJ	L3 DSVJ	d DSVJ	DSV Weight (kg)	DSVJ Weight (kg)	DSV/ DSVJType
65-40-315	22/2	YE2-180M-2	65	40	100	470	418	125	25	154	250	354	634	1325	1150	950	6-Φ24	1520	1344	1144	6-Φ24	368	374	TypeB/TypeB
	30/2	YE2-200L1-2	65	40	100	480	428	125	25	172	250	372	682	1410	1225	1025	6-Φ24	1605	1420	1220	6-Φ24	478	484	TypeB/TypeB
	37/2	YE2-200L2-2	65	40	100	480	428	125	25	172	250	372	682	1410	1225	1025	6-Φ24	1605	1420	1220	6-Φ24	495	501	TypeB/TypeB
	45/2	YE2-225M-2	65	40	100	510	458	125	25	179	250	379	704	1435	1300	1100	6-Φ24	1630	1424	1224	6-Φ24	549	555	TypeB/TypeB
	3/4	YE2-100L2-4	65	40	100	416	373	125	25	114	250	314	479	1015	900	700	4-Φ19	1210	1096	896	6-Φ19	236	242	TypeA/TypeB
	4/4	YE2-112M-4	65	40	100	446	403	125	25	114	250	314	502	1015	900	700	4-Φ19	1210	1096	896	6-Φ19	236	242	TypeA/TypeB
	5.5/4	YE2-132S-4	65	40	100	446	403	125	25	114	250	314	517	1100	980	780	4-Φ19	1295	1176	976	6-Φ19	267	273	TypeA/TypeB
	7.5/4	YE2-132M-4	65	40	100	446	403	125	25	114	250	314	517	1140	980	780	4-Φ19	1335	1176	976	6-Φ19	276	282	TypeA/TypeB

Installation Data

Model	Power/ Pole	Motor Model	DNs	DNt	L2	b2	b3	a	a2	h	h2	h3	h4	L DSV	L1 DSV	L3 DSV	d DSV	L DSVJ	L1 DSVJ	L3 DSVJ	d DSVJ	DSV Weight (kg)	DSVJ Weight (kg)	DSV/ DSVJType
80-65-125	3/2	YE2-100L-2	80	65	100	346	303	100	40	110	160	242	407	875	750	550	4-Φ19	1010	900	700	4-Φ19	129	133	TypeA/TypeA
	4/2	YE2-112M-2	80	65	100	346	303	100	40	114	160	246	434	885	765	565	4-Φ19	1020	903	703	4-Φ19	129	133	TypeA/TypeA
	5.5/2	YE2-132S1-2	80	65	100	341	298	100	40	114	160	246	449	960	850	650	4-Φ19	1095	927	727	4-Φ19	167	169	TypeA/TypeA
	7.5/2	YE2-132S2-2	80	65	100	341	298	100	40	114	160	246	449	960	850	650	4-Φ19	1095	927	727	4-Φ19	174	176	TypeA/TypeA
	0.37/4	YE2-71M2-4	80	65	100	330	295	100	40	73	140	205	/	740	645	445	4-Φ14	875	780	580	4-Φ14	96	99	TypeA/TypeA
	0.55/4	YE2-80M1-4	80	65	100	300	265	100	40	73	160	205	345	775	700	500	4-Φ14	910	835	635	4-Φ14	102	105	TypeA/TypeA
	0.75/4	YE2-80M2-4	80	65	100	300	265	100	40	73	160	205	345	775	700	500	4-Φ14	910	835	635	4-Φ14	104	107	TypeA/TypeA
	1.1/4	YE2-90S-4	80	65	100	312	277	100	40	73	160	205	360	810	710	510	4-Φ14	970	845	645	4-Φ14	109	112	TypeA/TypeA

Model	Power/ Pole	Motor Model	DNs	DNt	L2	b2	b3	a	a2	h	h2	h3	h4	L DSV	L1 DSV	L3 DSV	d DSV	L DSVJ	L1 DSVJ	L3 DSVJ	d DSVJ	DSV Weight (kg)	DSVJ Weight (kg)	DSV/ DSVJType
80-65-160	5.5/2	YE2-132S1-2	80	65	100	341	298	100	40	114	180	274	477	960	850	650	4-Φ19	1095	927	727	4-Φ19	175	177	TypeA/TypeA
	7.5/2	YE2-132S2-2	80	65	100	341	298	100	40	114	180	274	477	960	850	650	4-Φ19	1095	927	727	4-Φ19	182	184	TypeA/TypeA
	11/2	YE2-160M1-2	80	65	100	416	373	100	40	134	180	294	545	1102	990	790	4-Φ19	1237	1112	912	6-Φ19	241	245	TypeA/TypeB
	15/2	YE2-160M2-2	80	65	100	416	373	100	40	134	180	294	545	1102	990	790	4-Φ19	1237	1112	912	6-Φ19	255	259	TypeA/TypeB
	0.55/4	YE2-80M1-4	80	65	100	400	365	100	40	97	180	257	397	775	685	485	4-Φ14	910	820	620	4-Φ14	114	117	TypeA/TypeA
	0.75/4	YE2-80M2-4	80	65	100	400	365	100	40	97	180	257	397	775	685	485	4-Φ14	910	820	620	4-Φ14	115	118	TypeA/TypeA
	1.1/4	YE2-90S-4	80	65	100	400	365	100	40	97	180	257	412	810	730	530	4-Φ14	945	884	684	4-Φ14	124	127	TypeA/TypeA
	1.5/4	YE2-90L-4	80	65	100	400	365	100	40	97	180	257	412	835	730	530	4-Φ14	970	884	684	4-Φ14	128	131	TypeA/TypeA
	2.2/4	YE2-100L1-4	80	65	100	346	303	100	40	114	140	274	439	875	750	550	4-Φ19	1010	900	700	4-Φ19	140	144	TypeA/TypeA

Model	Power/ Pole	Motor Model	DNs	DNt	L2	b2	b3	a	a2	h	h2	h3	h4	L DSV	L1 DSV	L3 DSV	d DSV	L DSVJ	L1 DSVJ	L3 DSVJ	d DSVJ	DSV Weight (kg)	DSVJ Weight (kg)	DSV/ DSVJType
80-50-200	11/2	YE2-160M1-2	80	50	100	416	373	100	40	134	200	294	545	1102	990	790	4-Φ19	1237	1112	912	6-Φ19	247	251	TypeA/TypeB
	15/2	YE2-160M2-2	80	50	100	416	373	100	40	134	200	294	545	1102	990	790	4-Φ19	1237	1112	912	6-Φ19	261	265	TypeA/TypeB
	18.5/2	YE2-160L-2	80	50	100	416	373	100	40	134														

Installation Data

Model	Power/ Pole	Motor Model	DNs	DNt	L2	b2	b3	a	a2	h	h2	h3	h4	L DSV	L1 DSV	L3 DSV	d DSV	L DSVJ	L1 DSVJ	L3 DSVJ	d DSVJ	DSV Weight (kg)	DSVJ Weight (kg)	DSV/ DSVJType
80-50-250	15/2	YE2-160M2-2	80	50	100	446	403	125	25	114	225	294	545	1242	1140	940	6-Φ19	1481	1330	1130	6-Φ19	292	298	TypeB/TypeB
	18.5/2	YE2-160L-2	80	50	100	446	403	125	25	114	225	294	545	1286	1140	940	6-Φ19	1481	1330	1130	6-Φ19	314	320	TypeB/TypeB
	22/2	YE2-180M-2	80	50	100	470	418	125	25	154	225	334	614	1325	1150	950	6-Φ24	1520	1344	1144	6-Φ24	377	383	TypeB/TypeB
	30/2	YE2-200L1-2	80	50	100	480	428	125	25	172	225	352	662	1410	1225	1025	6-Φ24	1605	1420	1220	6-Φ24	433	439	TypeB/TypeB
	37/2	YE2-200L2-2	80	50	100	480	428	125	25	172	225	352	662	1410	1225	1025	6-Φ24	1605	1420	1220	6-Φ24	450	456	TypeB/TypeB
	2.2/4	YE2-100L1-4	80	50	100	416	373	125	25	114	225	294	459	1015	900	700	4-Φ19	1210	1096	896	6-Φ19	184	190	TypeA/TypeB
	3/4	YE2-100L2-4	80	50	100	416	373	125	25	114	225	294	459	1015	900	700	4-Φ19	1210	1096	896	6-Φ19	192	198	TypeA/TypeB
	4/4	YE2-112M-4	80	50	100	446	403	125	25	114	225	294	482	1015	900	700	4-Φ19	1210	1096	896	6-Φ19	206	212	TypeA/TypeB

Model	Power/ Pole	Motor Model	DNs	DNt	L2	b2	b3	a	a2	h	h2	h3	h4	L DSV	L1 DSV	L3 DSV	d DSV	L DSVJ	L1 DSVJ	L3 DSVJ	d DSVJ	DSV Weight (kg)	DSVJ Weight (kg)	DSV/ DSVJType
80-50-315	30/2	YE2-200L1-2	80	50	100	500	448	125	25	154	280	379	689	1410	1216	1016	6-Φ24	1605	1392	1192	6-Φ24	478	484	TypeB/TypeB
	37/2	YE2-200L2-2	80	50	100	500	448	125	25	154	280	379	689	1410	1216	1016	6-Φ24	1605	1392	1192	6-Φ24	495	501	TypeB/TypeB
	45/2	YE2-225M-2	80	50	100	510	458	125	25	154	280	379	704	1435	1300	1100	6-Φ24	1630	1424	1224	6-Φ24	550	556	TypeB/TypeB
	55/2	YE2-250M-2	80	50	100	596	535	125	25	219	280	444	804	1535	1370	1170	6-Φ28	1730	1508	1308	6-Φ28	699	705	TypeB/TypeB
	75/2	YE2-280S-2	80	50	100	650	589	125	25	251	280	476	866	1600	1380	1180	6-Φ28	1795	1556	1356	6-Φ28	859	865	TypeB/TypeB
	4/4	YE2-112M-4	80	50	100	456	413	125	25	114	280	339	527	1015	930	730	4-Φ19	1210	1126	926	6-Φ19	206	212	TypeA/TypeB
	5.5/4	YE2-132S-4	80	50	100	446	403	125	25	114	280	339	542	1100	1010	810	6-Φ19	1295	1206	1006	6-Φ19	279	285	TypeB/TypeB
	7.5/4	YE2-132M-4	80	50	100	446	403	125	25	114	280	339	542	1140	1010	810	6-Φ19	1335	1206	1006	6-Φ19	288	294	TypeB/TypeB
	11/4	YE2-160M-4	80	50	100	446	403	125	25	114	280	339	542	1242	1140	940	6-Φ19	1437	1330	1130	6-Φ19	340	346	TypeB/TypeB

Model	Power/ Pole	Motor Model	DNs	DNt	L2	b2	b3	a	a2	h	h2	h3	h4	L DSV	L1 DSV	L3 DSV	d DSV	L DSVJ	L1 DSVJ	L3 DSVJ	d DSVJ	DSV Weight (kg)	DSVJ Weight (kg)	DSV/ DSVJType
100-80-125	4/2	YE2-112M-2	100	80	100	346	303	100	25	114	180	274	462	885	765	565	4-Φ19	1020	903	703	4-Φ19	152	156	TypeA/TypeA
	5.5/2	YE2-132S1-2	100	80	100	341	298	100	25	114	180	274	477	960	850	650	4-Φ19	1095	945	745	4-Φ19	177	179	TypeA/TypeA
	7.5/2	YE2-132S2-2	100	80	100	341	298	100	25	114	180	274	477	960	850	650	4-Φ19	1095	945	745	4-Φ19	187	189	TypeA/TypeA
	11/2	YE2-160M1-2	100	80	100	416	373	100	25	134	180	294	545	1102	990	790	4-Φ19	1237	1134	934	6-Φ19	245	249	TypeA/TypeB
	0.55/4	YE2-80M1-4	100	80	100	400	365	100	25	97	180	257	397	775	685	485	4-Φ14	910	820	620	4-Φ14	117	120	TypeA/TypeA
	0.75/4	YE2-80M2-4	100	80	100	400	365	100	25	97	180	257	397	775	685	485	4-Φ14	910	820	620	4-Φ14	118	121	TypeA/TypeA
	1.1/4	YE2-90S-4	100	80	100	400	365	100	25	97	180	257	412	810	730	530	4-Φ14	945	884	684	4-Φ14	127	130	TypeA/TypeA

Installation Data

Model	Power/ Pole	Motor Model	DNs	DNt	L2	b2	b3	a	a2	h	h2	h3	h4	L DSV	L1 DSV	L3 DSV	d DSV	L DSVJ	L1 DSVJ	L3 DSVJ	d DSVJ	DSV Weight (kg)	DSVJ Weight (kg)	DSV/ DSVJType
100-80-160	7.5/2	YE2-132S2-2	100	80	100	341	298	100	25	114	200	274	477	960	850	650	4-Φ19	1095	945	745	4-Φ19	216	218	TypeA/TypeA
	11/2	YE2-160M1-2	100	80	100	416	373	100	25	134	200	294	545	1102	990	790	4-Φ19	1237	1134	934	6-Φ19	269	273	TypeA/TypeB
	15/2	YE2-160M2-2	100	80	100	416	373	100	25	134	200	294	545	1102	990	790	4-Φ19	1237	1134	934	6-Φ19	283	287	TypeA/TypeB
	18.5/2	YE2-160L-2	100	80	100	416	373	100	25	134	200	294	545	1146	990	790	4-Φ19	1281	1134	934	6-Φ19	305	309	TypeA/TypeB
	0.75/4	YE2-80M2-4	100	80	100	400	365	100	25	97	200	257	397	775	685	485	4-Φ14	910	820	620	4-Φ14	138	141	TypeA/TypeA
	1.1/4	YE2-90S-4	100	80	100	400	365	100	25	97	200	257	412	810	730	530	4-Φ14	945	884	684	4-Φ14	147	150	TypeA/TypeA
	1.5/4	YE2-90L-4	100	80	100	400	365	100	25	97	200	257	412	835	730	530	4-Φ14	970	884	684	4-Φ14	151	154	TypeA/TypeA
	2.2/4	YE2-100L1-4	100	80	100	346	303	100	25	114	200	274	439	875	765	565	4-Φ19	1010	900	700	4-Φ19	176	180	TypeA/TypeA

Model	Power/ Pole	Motor Model	DNs	DNt	L2	b2	b3	a	a2	h	h2	h3	h4	L DSV	L1 DSV	L3 DSV	d DSV	L DSVJ	L1 DSVJ	L3 DSVJ	d DSVJ	DSV Weight (kg)	DSVJ Weight (kg)	DSV/ DSVJType
100-65-200	11/2	YE2-160M1-2	100	65	100	446	403	100	25	114	225	294	545	1217	1140	940	6-Φ19	1412	1330	1130	6-Φ19	273	279	TypeB/TypeB
	15/2	YE2-160M2-2	100	65	100	446	403	100	25	114	225	294	545	1217	1140	940	6-Φ19	1412	1330	1130	6-Φ19	287	293	TypeB/TypeB
	18.5/2	YE2-160L-2	100	65	100	446	403	100	25	114	225	294	545	1261	1140	940	6-Φ19	1456	1330	1130	6-Φ19	308	314	TypeB/TypeB
	22/2	YE2-180M-2	100	65	100	470	418	100	25	154	225	334	614	1300	1150	950	6-Φ24	1495	1344	1144	6-Φ24	371	377	TypeB/TypeB
	30/2	YE2-200L1-2	100	65	100	480	428	100	25	172	225	352	662	1385	1225	1025	6-Φ24	1580	1420	1220	6-Φ24	428	434	TypeB/TypeB
	37/2	YE2-200L2-2	100	65	100	480	428	100	25	172	225	352	662	1385	1225	1025	6-Φ24	1580	1420	1220	6-Φ24	445	451	TypeB/TypeB
	1.5/4	YE2-90L-4	100	65	100	400	365	100	25	77	225	257	412	950	840	640	4-Φ14	1145	1036	836	6-Φ14	156	162	TypeA/TypeB
	2.2/4	YE2-100L1-4	100	65	100	416	373	100	25	114	225	294	459	990	900	700	4-Φ19	1185	1096	896	6-Φ19	179	185	TypeA/TypeB
	3/4	YE2-100L2-4	100	65	100	416	373	100	25	114	225	294	459	990	900	700	4-Φ19	1185	1096	896	6-Φ19	187	193	TypeA/TypeB
	4/4	YE2-112M-4	100	65	100	446	403	100	25	114	225	294	482	990	900	700	4-Φ19	1185	1096	896	6-Φ19	244	250	TypeA/TypeB

Model	Power/ Pole	Motor Model	DNs	DNt	L2	b2	b3	a	a2	h	h2	h3	h4	L DSV	L1 DSV	L3 DSV	d DSV	L DSVJ	L1 DSVJ	L3 DSVJ	d DSVJ	DSV Weight (kg)	DSVJ Weight (kg)	DSV/ DSVJType
100-65-250	30/2	YE2-200L1-2	100	65	100	480	428	125	10	172	250	372	682	1410	1225	1025	6-Φ24	1605	1420	1220	6-Φ24	470	476	TypeB/TypeB
	37/2																							

Installation Data

Model	Power/ Pole	Motor Model	DNs	DNt	L2	b2	b3	a	a2	h	h2	h3	h4	L DSV	L1 DSV	L3 DSV	d DSV	L DSVJ	L1 DSVJ	L3 DSVJ	d DSVJ	DSV Weight (kg)	DSVJ Weight (kg)	DSV/ DSVJType
100-65-315	55/2	YE2-250M-2	100	65	100	596	535	125	10	219	280	444	804	1565	1370	1170	6-Φ28	1760	1540	1340	6-Φ28	716	722	TypeB/TypeB
	75/2	YE2-280S-2	100	65	100	647	586	125	10	251	280	476	866	1630	1460	1260	6-Φ28	1825	1670	1470	6-Φ28	871	877	TypeB/TypeB
	90/2	YE2-280M-2	100	65	100	647	586	125	10	251	280	476	866	1680	1460	1260	6-Φ28	1875	1670	1470	6-Φ28	923	929	TypeB/TypeB
	110/2	YE2-315S-2	100	65	100	702	641	125	10	288	280	513	1018	1780	1600	1400	6-Φ28	1975	1814	1614	6-Φ28	1279	1285	TypeB/TypeB
	5.5/4	YE2-132S-4	100	65	100	446	403	125	10	114	280	339	542	1130	1010	810	6-Φ19	1325	1206	1006	6-Φ19	296	302	TypeB/TypeB
	7.5/4	YE2-132M-4	100	65	100	446	403	125	10	114	280	339	542	1170	1010	810	6-Φ19	1365	1206	1006	6-Φ19	305	311	TypeB/TypeB
	11/4	YE2-160M-4	100	65	100	446	403	125	10	114	280	339	590	1272	1140	940	6-Φ19	1467	1330	1130	6-Φ19	353	359	TypeB/TypeB
	15/4	YE2-160L-4	100	65	100	446	403	125	10	114	280	339	590	1316	1140	940	6-Φ19	1511	1330	1130	6-Φ19	369	375	TypeB/TypeB

Model	Power/ Pole	Motor Model	DNs	DNt	L2	b2	b3	a	a2	h	h2	h3	h4	L DSV	L1 DSV	L3 DSV	d DSV	L DSVJ	L1 DSVJ	L3 DSVJ	d DSVJ	DSV Weight (kg)	DSVJ Weight (kg)	DSV/ DSVJType
125-80-160	11/2	YE2-160M1-2	125	80	100	446	403	125	25	114	225	294	545	1242	1140	940	6-Φ19	1437	1330	1130	6-Φ19	274	280	TypeB/TypeB
	15/2	YE2-160M2-2	125	80	100	446	403	125	25	114	225	294	545	1242	1140	940	6-Φ19	1437	1330	1130	6-Φ19	288	294	TypeB/TypeB
	18.5/2	YE2-160L-2	125	80	100	446	403	125	25	114	225	294	545	1286	1140	940	6-Φ19	1481	1330	1130	6-Φ19	309	315	TypeB/TypeB
	22/2	YE2-180M-2	125	80	100	470	418	125	25	154	225	334	614	1325	1150	950	6-Φ24	1520	1344	1144	6-Φ24	372	378	TypeB/TypeB
	30/2	YE2-200L1-2	125	80	100	480	428	125	25	172	225	352	662	1410	1225	1025	6-Φ24	1605	1420	1220	6-Φ24	428	434	TypeB/TypeB
	1.5/4	YE2-90L-4	125	80	100	400	365	125	25	77	225	257	412	975	840	640	4-Φ14	1170	1036	836	6-Φ14	157	163	TypeA/TypeB
	2.2/4	YE2-100L1-4	125	80	100	416	373	125	25	114	225	294	459	1015	900	700	4-Φ19	1210	1096	896	6-Φ19	180	186	TypeA/TypeB
	3/4	YE2-100L2-4	125	80	100	416	373	125	25	114	225	294	459	1015	900	700	4-Φ19	1210	1096	896	6-Φ19	188	194	TypeA/TypeB
	4/4	YE2-112M-4	125	80	100	446	403	125	25	114	225	294	482	1015	900	700	4-Φ19	1210	1096	896	6-Φ19	202	208	TypeA/TypeB

Model	Power/ Pole	Motor Model	DNs	DNt	L2	b2	b3	a	a2	h	h2	h3	h4	L DSV	L1 DSV	L3 DSV	d DSV	L DSVJ	L1 DSVJ	L3 DSVJ	d DSVJ	DSV Weight (kg)	DSVJ Weight (kg)	DSV/ DSVJType
125-80-200	22/2	YE2-180M-2	125	80	100	470	418	125	25	154	250	334	614	1325	1150	950	6-Φ24	1520	1344	1144	6-Φ24	387	393	TypeB/TypeB
	30/2	YE2-200L1-2	125	80	100	480	428	125	25	172	250	352	662	1410	1225	1025	6-Φ24	1605	1420	1220	6-Φ24	445	451	TypeB/TypeB
	37/2	YE2-200L2-2	125	80	100	480	428	125	25	172	250	352	662	1410	1225	1025	6-Φ24	1605	1420	1220	6-Φ24	462	468	TypeB/TypeB
	45/2	YE2-225M-2	125	80	100	510	458	125	25	197	250	377	702	1435	1300	1100	6-Φ24	1630	1424	1224	6-Φ24	515	521	TypeB/TypeB
	55/2	YE2-250M-2	125	80	100	596	535	125	25	266	250	446	806	1535	1330	1130	6-Φ28	1730	1500	1300	6-Φ28	668	674	TypeB/TypeB
	2.2/4	YE2-100L1-4	125	80	100	416	373	125	25	114	250	294	459	1015	900	700	4-Φ19	1210	1096	896	6-Φ19	194	200	TypeA/TypeB
	3/4	YE2-100L2-4	125	80	100	416	373	125	25	114	250	294	459	1015	900	700	4-Φ19	1110	1096	896	6-Φ19	202	208	TypeA/TypeB
	4/4	YE2-112M-4	125	80	100	446	403	125	25	114	250	294	482	1015	900	700	4-Φ19	1210	1096	896	6-Φ19	219	225	TypeA/TypeB
	5.5/4	YE2-132S-4	125	80	100	446	403	125	25	114	250	294	497	1100	980	780	4-Φ19	1295	1176	976	6-Φ19	238	244	TypeA/TypeB
	7.5/4	YE2-132M-4	125	80	100	446	403	125	25	114	250	294	497	1140	980	780	4-Φ19	1335	1176	976	6-Φ19	247	253	TypeA/TypeB

Installation Data

Model	Power/ Pole	Motor Model	DNs	DNt	L2	b2	b3	a	a2	h	h2	h3	h4	L DSV	L1 DSV	L3 DSV	d DSV	L DSVJ	L1 DSVJ	L3 DSVJ	d DSVJ	DSV Weight (kg)	DSVJ Weight (kg)	DSV/ DSVJType
125-80-250	45/2	YE2-225M-2	125	80	100	510	458	125	10	154	280	379	704	1435	1300	1100	6-Φ24	1630	1424	1224	6-Φ24	540	546	TypeB/TypeB
	55/2	YE2-250M-2	125	80	100	596	535	125	10	219	280	444	804	1535	1370	1170	6-Φ28	1730	1508	1308	6-Φ28	690	696	TypeB/TypeB
	75/2	YE2-280S-2	125	80	100	650	589	125	10	251	280	476	866	1600	1460	1260	6-Φ28	1795	1640	1440	6-Φ28	844	850	TypeB/TypeB
	90/2	YE2-280M-2	125	80	100	650	589	125	10	251	280	476	866	1650	1460	1260	6-Φ28	1845	1640	1440	6-Φ28	897	903	TypeB/TypeB
	5.5/4	YE2-132S-4	125	80	100	446	403	125	10	114	280	339	542	1100	1010	810	6-Φ19	1295	1206	1006	6-Φ19	270	276	TypeB/TypeB
	7.5/4	YE2-132M-4	125	80	100	446	403	125	10	114	280	339	542	1140	1010	810	6-Φ19	1335	1206	1006	6-Φ19	279	285	TypeB/TypeB
	11/4	YE2-160M-4	125	80	100	446	403	125	10	114	280	339	590	1242	1140	940	6-Φ19	1437	1330	1130	6-Φ19	328	334	TypeB/TypeB

Model	Power/ Pole	Motor Model	DNs	DNt	L2	b2	b3	a	a2	h	h2	h3	h4	L DSV	L1 DSV	L3 DSV	d DSV	L DSVJ	L1 DSVJ	L3 DSVJ	d DSVJ	DSV Weight (kg)	DSVJ Weight (kg)	DSV/ DSVJType
125-80-315	90/2	YE2-280M-2	125	80	100	647	586	125	10	251	315	501	891	1680	1460	1260	6-Φ28	1875	1670	1470	6-Φ28	957	963	TypeB/TypeB
	110/2	YE2-315S-2	125	80	100	702	641	125	10	288	315	538	1043	1780	1600	1400	6-Φ28	1975	1814	1614	6-Φ28	1302	1308	TypeB/TypeB
	132/2	YE2-315M-2	125	80	100	702	641	125	10	288	315	538	1043	1960	1600	1400	6-Φ28	2155	1814	1614	6-Φ28	1413	1419	TypeB/TypeB
	160/2	YE2-315L1-2	125	80	100	702	641	125	10	288	315	538	1043	1960	1600	1400	6-Φ28	2155	1814	1614	6-Φ28	1517	1523	TypeB/TypeB
	200/2	YE2-315L2-2	125	80	100	702	641	125	10	288	315	538	1043	1960	1600	1400	6-Φ28	2155	1814	1614	6-Φ28	1490	1496	TypeB/TypeB
	11/4	YE2-160M-4	125	80	100	446	403	125	10	114	315	364	615	1272	1140	940	6-Φ19	1467	1336	1136	6-Φ19	377	383	TypeB/TypeB
	15/4	YE2-160L-4	125	80	100	446	403	125	10	114	315	364	615	1316	1140	940	6-Φ19	1511	1336	1136	6-Φ19	394	400	TypeB/TypeB
	18.5/4	YE2-180M-4	125	80	100	489	437	125	10	154	315	404	684	1355	1180	980	6-Φ24	1550	1400	1200	6-Φ24	457	463	TypeB/TypeB
	22/4	YE2-180L-4	125	80	100	489	437	125	10	154	315	404	684	1390	1180	980	6-Φ24	1585	1400	1200	6-Φ24	488	494	TypeB/TypeB

Model	Power/ Pole	Motor Model	DNs	DNt	L2	b2	b3	a	a2	h	h2	h3	h4	L DSV	L1 DSV	L3 DSV	d DSV	L DSVJ	L1 DSVJ	L3 DSVJ
-------	----------------	----------------	-----	-----	----	----	----	---	----	---	----	----	----	----------	-----------	-----------	----------	-----------	------------	------------

Installation Data

Model	Power/ Pole	Motor Model	DNs	DNt	L2	b2	b3	a	a2	h	h2	h3	h4	L DSV	L1 DSV	L3 DSV	d DSV	L DSVJ	L1 DSVJ	L3 DSVJ	d DSVJ	DSV Weight (kg)	DSVJ Weight (kg)	DSV/ DSVJType
125-100-160	22/2	YE2-180M-2	125	100	100	470	418	125	10	154	280	354	634	1325	1150	950	6-Φ24	1520	1344	1144	6-Φ24	368	374	TypeB/TypeB
	30/2	YE2-200L1-2	125	100	100	480	428	125	10	172	280	372	682	1410	1225	1025	6-Φ24	1605	1420	1220	6-Φ24	452	458	TypeB/TypeB
	37/2	YE2-200L2-2	125	100	100	480	428	125	10	172	280	372	682	1410	1225	1025	6-Φ24	1605	1420	1220	6-Φ24	469	475	TypeB/TypeB
	2.2/4	YE2-100L1-4	125	100	100	416	373	125	10	114	280	314	479	1015	900	700	4-Φ19	1210	1096	896	6-Φ19	203	209	TypeA/TypeB
	3/4	YE2-100L2-4	125	100	100	416	373	125	10	114	280	314	479	1015	900	700	4-Φ19	1210	1096	896	6-Φ19	211	217	TypeA/TypeB
	4/4	YE2-112M-4	125	100	100	446	403	125	10	114	280	314	502	1015	900	700	4-Φ19	1210	1096	896	6-Φ19	226	232	TypeA/TypeB

Model	Power/ Pole	Motor Model	DNs	DNt	L2	b2	b3	a	a2	h	h2	h3	h4	L DSV	L1 DSV	L3 DSV	d DSV	L DSVJ	L1 DSVJ	L3 DSVJ	d DSVJ	DSV Weight (kg)	DSVJ Weight (kg)	DSV/ DSVJType
125-100-200	30/2	YE2-200L1-2	125	100	100	480	428	125	10	172	280	372	682	1410	1225	1025	6-Φ24	1605	1420	1220	6-Φ24	464	470	TypeB/TypeB
	37/2	YE2-200L2-2	125	100	100	480	428	125	10	172	280	372	682	1410	1225	1025	6-Φ24	1605	1420	1220	6-Φ24	481	487	TypeB/TypeB
	45/2	YE2-225M-2	125	100	100	510	458	125	10	179	280	379	704	1435	1300	1100	6-Φ24	1630	1424	1224	6-Φ24	538	544	TypeB/TypeB
	55/2	YE2-250M-2	125	100	100	596	535	125	10	244	280	444	804	1535	1370	1170	6-Φ28	1730	1508	1308	6-Φ28	694	700	TypeB/TypeB
	75/2	YE2-280S-2	125	100	100	650	589	125	10	276	280	476	866	1600	1380	1180	6-Φ28	1795	1556	1356	6-Φ28	845	851	TypeB/TypeB
	4/4	YE2-112M-4	125	100	100	446	403	125	10	114	280	314	502	1015	900	700	4-Φ19	1210	1096	896	6-Φ19	238	244	TypeA/TypeB
	5.5/4	YE2-132S-4	125	100	100	446	403	125	10	114	280	314	517	1100	980	780	4-Φ19	1295	1176	976	6-Φ19	254	260	TypeA/TypeB
	7.5/4	YE2-132M-4	125	100	100	446	403	125	10	114	280	314	517	1140	980	780	4-Φ19	1335	1176	976	6-Φ19	263	269	TypeA/TypeB
	11/4	YE2-160M-4	125	100	100	446	403	125	10	114	280	314	565	1242	1140	940	6-Φ19	1437	1362	1162	6-Φ19	311	317	TypeB/TypeB

Model	Power/ Pole	Motor Model	DNs	DNt	L2	b2	b3	a	a2	h	h2	h3	h4	L DSV	L1 DSV	L3 DSV	d DSV	L DSVJ	L1 DSVJ	L3 DSVJ	d DSVJ	DSV Weight (kg)	DSVJ Weight (kg)	DSV/ DSVJType
125-100-250	55/2	YE2-250M-2	125	100	100	596	535	140	10	219	280	444	804	1580	1370	1170	6-Φ28	1775	1540	1340	6-Φ28	703	709	TypeB/TypeB
	75/2	YE2-280S-2	125	100	100	647	586	140	10	251	280	476	866	1645	1460	1260	6-Φ28	1840	1670	1470	6-Φ28	859	865	TypeB/TypeB
	90/2	YE2-280M-2	125	100	100	647	586	140	10	251	280	476	866	1695	1460	1260	6-Φ28	1890	1670	1470	6-Φ28	910	916	TypeB/TypeB
	110/2	YE2-315S-2	125	100	100	702	641	140	10	288	280	513	1018	1795	1600	1400	6-Φ28	1990	1814	1614	6-Φ28	1267	1273	TypeB/TypeB
	132/2	YE2-315M-2	125	100	100	702	641	140	10	288	280	513	1018	1975	1600	1400	6-Φ28	2170	1814	1614	6-Φ28	1373	1379	TypeB/TypeB
	7.5/4	YE2-132M-4	125	100	100	446	403	140	10	114	280	339	542	1185	1010	810	6-Φ19	1380	1206	1006	6-Φ19	292	298	TypeB/TypeB
	11/4	YE2-160M-4	125	100	100	446	403	140	10	114	280	339	590	1287	1140	940	6-Φ19	1482	1330	1130	6-Φ19	341	347	TypeB/TypeB
	15/4	YE2-160L-4	125	100	100	446	403	140	10	114	280	339	590	1331	1140	940	6-Φ19	1526	1330	1130	6-Φ19	357	363	TypeB/TypeB
	18.5/4	YE2-180M-4	125	100	100	489	437	140	10	154	280	379	659	1370	1180	980	6-Φ24	1565	1400	1200	6-Φ24	419	425	TypeB/TypeB

Installation Data

Model	Power/ Pole	Motor Model	DNs	DNt	L2	b2	b3	a	a2	h	h2	h3	h4	L DSV	L1 DSV	L3 DSV	d DSV	L DSVJ	L1 DSVJ	L3 DSVJ	d DSVJ	DSV Weight (kg)	DSVJ Weight (kg)	DSV/ DSVJType
125-100-315	110/2	YE2-315S-2	125	100	100	702	641	140	10	288	315	538	1043	1795	1600	1400	6-Φ28	1990	1814	1614	6-Φ28	1306	1312	TypeB/TypeB
	132/2	YE2-315M-2	125	100	100	702	641	140	10	288	315	538	1043	1975	1600	1400	6-Φ28	2170	1814	1614	6-Φ28	1416	1422	TypeB/TypeB
	160/2	YE2-315L1-2	125	100	100	702	641	140	10	288	315	538	1043	1975	1600	1400	6-Φ28	2170	1814	1614	6-Φ28	1521	1527	TypeB/TypeB
	200/2	YE2-315L2-2	125	100	100	702	641	140	10	288	315	538	1043	1975	1600	1400	6-Φ28	2170	1814	1614	6-Φ28	1561	1567	TypeB/TypeB
	15/4	YE2-160L-4	125	100	100	446	403	140	10	114	315	364	615	1331	1140	940	6-Φ19	1526	1336	1136	6-Φ19	399	405	TypeB/TypeB
	18.5/4	YE2-180M-4	125	100	100	489	437	140	10	154	315	404	684	1370	1180	980	6-Φ24	1565	1400	1200	6-Φ24	461	467	TypeB/TypeB
	22/4	YE2-180L-4	125	100	100	489	437	140	10	154	315	404	684	1405	1180	980	6-Φ24	1600	1400	1200	6-Φ24	482	488	TypeB/TypeB
	30/4	YE2-200L-4	125	100	100	500	448	140	10	154	315	404	714	1455	1216	1016	6-Φ24	1650	1410	1210	6-Φ24	553	559	TypeB/TypeB

Model	Power/ Pole	Motor Model	DNs	DNt	L2	b2	b3	a	a2	h	h2	h3	h4	L DSV	L1 DSV	L3 DSV	d DSV	L DSVJ	L1 DSVJ	L3 DSVJ	d DSVJ	DSV Weight (kg)	DSVJ Weight (kg)	DSV/ DSVJType
125-100-400	22/4	YE2-180L-4	125	100	100	610	558	140	-10	160	355	440	720	1405	1200	1000	6-Φ24	1600	1420	1220	6-Φ24	566	572	TypeB/TypeB
	30/4	YE2-200L-4	125	100	100	610	558	140	-10	156	355	436	746	1455	1240	1040	6-Φ24	1650	1458	1258	6-Φ24	636	642	TypeB/TypeB
	37/4	YE2-225S-4	125	100	100	610	558	140	-10	160	355	440	765	1485	1310	1110	6-Φ24	1680	1504	1304	6-Φ24	692	698	TypeB/TypeB
	45/4	YE2-225M-4	125	100	100	610	558	140	-10	160	355	440	765	1510	1310	1110	6-Φ24	1705	1504	1304	6-Φ24	708	714	TypeB/TypeB
	55/4	YE2-250M-4	125	100	100	644	583	140	-10	196	355	476	836	1580	1390	1190	6-Φ28	1775	1560	1360	6-Φ28	848	854	TypeB/TypeB

Model	Power/ Pole	Motor Model	DNs	DNt	L2	b2	b3	a	a2	h	h2	h3	h4	L DSV	L1 DSV	L3 DSV	d DSV	L DSVJ	L1 DSVJ	L3 DSVJ	d DSVJ	DSV Weight (kg)	DSVJ Weight (kg)	DSV/ DSVJType
150-125-200	45/2	YE2-225M-2	150	125	100	510	458	140	10	154	315	404	729	1450	1300	1100	6-Φ24	1645	1424	1224	6-Φ24	584	590	TypeB/TypeB
	55/2	YE2-250M-2	150	125	100	596	535	140	10	219	315	469	829	1550	1370	1170	6-Φ28	1745	1508	1308	6-Φ28	755	761	TypeB/TypeB
	75/2	YE2-280S-2	150	125	100	650	589	140	10	251	315	501	891	1615	1460	1260	6-Φ28	1810	1640	1440	6-Φ28	903	909	TypeB/TypeB
	90/2	YE2-280M-2	150	125	100	650	589	140	10	251	315	501	891	1665	1460	1260	6-Φ28	1860	1640	1440	6-Φ28	964	970	TypeB/TypeB
	110/2	YE2-315S-2	150	125	100	702	641	140	10	288	315	538	1043	1765	1600	1400	6-Φ28	1960	1814	1614	6-Φ28	1279	1285	TypeB/TypeB
	5.5/4	YE2-132S-4	150	125	100	446	403	140																

Installation Data

Model	Power/ Pole	Motor Model	DNs	DNt	L2	b2	b3	a	a2	h	h2	h3	h4	L DSV	L1 DSV	L3 DSV	d DSV	L DSVJ	L1 DSVJ	L3 DSVJ	d DSVJ	DSV Weight (kg)	DSVJ Weight (kg)	DSV/ DSVJType
150-125-250	90/2	YE2-280M-2	150	125	100	647	586	140	10	251	355	501	891	1695	1460	1260	6-Φ28	1890	1670	1470	6-Φ28	981	987	TypeB/TypeB
	110/2	YE2-315S-2	150	125	100	702	641	140	10	288	355	538	1043	1795	1600	1400	6-Φ28	1990	1814	1614	6-Φ28	1251	1257	TypeB/TypeB
	132/2	YE2-315M-2	150	125	100	702	641	140	10	288	355	538	1043	1975	1600	1400	6-Φ28	2170	1814	1614	6-Φ28	1426	1432	TypeB/TypeB
	160/2	YE2-315L1-2	150	125	100	702	641	140	10	288	355	538	1043	1975	1600	1400	6-Φ28	2170	1814	1614	6-Φ28	1591	1597	TypeB/TypeB
	200/2	YE2-315L2-2	150	125	100	702	641	140	10	288	355	538	1043	1975	1600	1400	6-Φ28	2170	1814	1614	6-Φ28	1621	1627	TypeB/TypeB
	11/4	YE2-160M-4	150	125	100	446	403	140	10	114	355	364	615	1287	1140	940	6-Φ19	1482	1336	1136	6-Φ19	376	382	TypeB/TypeB
	15/4	YE2-160L-4	150	125	100	446	403	140	10	114	355	364	615	1331	1140	940	6-Φ19	1526	1336	1136	6-Φ19	394	400	TypeB/TypeB
	18.5/4	YE2-180M-4	150	125	100	489	437	140	10	154	355	404	684	1370	1180	980	6-Φ24	1565	1400	1200	6-Φ24	456	462	TypeB/TypeB
	22/4	YE2-180L-4	150	125	100	489	437	140	10	154	355	404	684	1405	1180	980	6-Φ24	1600	1400	1200	6-Φ24	477	483	TypeB/TypeB
	30/4	YE2-200L-4	150	125	100	500	448	140	10	154	355	404	714	1455	1216	1016	6-Φ24	1650	1410	1210	6-Φ24	548	554	TypeB/TypeB

Model	Power/ Pole	Motor Model	DNs	DNt	L2	b2	b3	a	a2	h	h2	h3	h4	L DSV	L1 DSV	L3 DSV	d DSV	L DSVJ	L1 DSVJ	L3 DSVJ	d DSVJ	DSV Weight (kg)	DSVJ Weight (kg)	DSV/ DSVJType
150-125-315	132/2	YE2-315M-2	150	125	100	702	641	140	-10	231	355	511	1016	1975	1600	1400	6-Φ28	2170	1814	1614	6-Φ28	1434	1440	TypeB/TypeB
	160/2	YE2-315L1-2	150	125	100	702	641	140	-10	231	355	511	1016	1975	1600	1400	6-Φ28	2170	1814	1614	6-Φ28	1600	1606	TypeB/TypeB
	200/2	YE2-315L2-2	150	125	100	702	641	140	-10	231	355	511	1016	1975	1600	1400	6-Φ28	2170	1814	1614	6-Φ28	1630	1636	TypeB/TypeB
	250/2	YE2-355M-2	150	125	100	800	739	140	-10	275	355	555	1210	2165	1800	1600	6-Φ28	2360	2000	1800	8-Φ28	2119	2125	TypeB/TypeC
	18.5/4	YE2-180M-4	150	125	100	610	558	140	-10	160	355	440	720	1370	1200	1000	6-Φ24	1565	1420	1220	6-Φ24	508	514	TypeB/TypeB
	22/4	YE2-180L-4	150	125	100	610	558	140	-10	160	355	440	720	1405	1200	1000	6-Φ24	1600	1420	1220	6-Φ24	526	532	TypeB/TypeB
	30/4	YE2-200L-4	150	125	100	610	558	140	-10	156	355	436	746	1455	1240	1040	6-Φ24	1650	1458	1258	6-Φ24	596	602	TypeB/TypeB
	37/4	YE2-225S-4	150	125	100	610	558	140	-10	160	355	440	765	1485	1310	1110	6-Φ24	1680	1504	1304	6-Φ24	652	658	TypeB/TypeB
	45/4	YE2-225M-4	150	125	100	610	558	140	-10	160	355	440	765	1510	1310	1110	6-Φ24	1705	1504	1304	6-Φ24	668	674	TypeB/TypeB

Model	Power/ Pole	Motor Model	DNs	DNt	L2	b2	b3	a	a2	h	h2	h3	h4	L DSV	L1 DSV	L3 DSV	d DSV	L DSVJ	L1 DSVJ	L3 DSVJ	d DSVJ	DSV Weight (kg)	DSVJ Weight (kg)	DSV/ DSVJType
150-125-400	37/4	YE2-225S-4	150	125	100	610	558	140	-10	160	400	475	800	1485	1310	1110	6-Φ24	1680	1504	1304	6-Φ24	720	726	TypeB/TypeB
	45/4	YE2-225M-4	150	125	100	610	558	140	-10	160	400	475	800	1510	1310	1110	6-Φ24	1705	1504	1304	6-Φ24	736	742	TypeB/TypeB
	55/4	YE2-250M-4	150	125	100	630	569	140	-10	196	400	511	871	1580	1370	1170	6-Φ28	1775	1560	1360	6-Φ28	923	929	TypeB/TypeB
	75/4	YE2-280S-4	150	125	100	660	599	140	-10	196	400	511	901	1645	1520	1320	6-Φ28	1840	1660	1460	6-Φ28	996	1002	TypeB/TypeB
	90/4	YE2-280M-4	150	125	100	660	599	140	-10	196	400	511	901	1695	1520	1320	6-Φ28	1890	1660	1460	6-Φ28	1117	1123	TypeB/TypeB

Installation Data

Model	Power/ Pole	Motor Model	DNs	DNt	L2	b2	b3	a	a2	h	h2	h3	h4	L DSV	L1 DSV	L3 DSV	d DSV	L DSVJ	L1 DSVJ	L3 DSVJ	d DSVJ	DSV Weight (kg)	DSVJ Weight (kg)	DSV/ DSVJType
150-125-500	55/4	YE2-250M-4	150	125	100	680	619	180	-10	196	500	596	956	1760	1530	1330	6-Φ28	2025	1800	1600	6-Φ28	1135	1145	TypeB/TypeB
	75/4	YE2-280S-4	150	125	100	690	629	180	-10	196	500	596	986	1825	1660	1460	6-Φ28	2090	1920	1720	6-Φ28	1343	1353	TypeB/TypeB
	90/4	YE2-280M-4	150	125	100	690	629	180	-10	196	500	596	986	1875	1660	1460	6-Φ28	2140	1920	1720	6-Φ28	1464	1474	TypeB/TypeB
	110/4	YE2-315S-4	150	125	100	690	629	180	-10	196	500	596	1101	1975	1850	1650	6-Φ28	2240	2056	1856	8-Φ28	1716	1726	TypeB/TypeC
	132/4	YE2-315M-4	150	125	100	690	629	180	-10	196	500	596	1101	2155	1850	1650	6-Φ28	2420	2056	1856	8-Φ28	1859	1869	TypeB/TypeC
	160/4	YE2-315L1-4	150	125	100	690	629	180	-10	196	500	596	1101	2155	1850	1650	6-Φ28	2420	2056	1856	8-Φ28	1953	1963	TypeB/TypeC
		YE2-315L2-4	150	125	100	690	629	180	-10	196	500	596	1101	2155	1850	1650	6-Φ28	2420	2056	1856	8-Φ28	1953	1963	TypeB/TypeC

Model	Power/ Pole	Motor Model	DNs	DNt	L2	b2	b3	a	a2	h	h2	h3	h4	L DSV	L1 DSV	L3 DSV	d DSV	L DSVJ	L1 DSVJ	L3 DSVJ	d DSVJ	DSV Weight (kg)	DSVJ Weight (kg)	DSV/ DSVJType
200-150-200	75/2	YE2-280S-2	200	150	100	637	576	160	-10	196	400	476	866	1635	1520	1320	6-Φ28	1830	1720	1520	6-Φ28	903	909	TypeB/TypeB
	90/2	YE2-280M-2	200	150	100	637	576	160	-10	196	400	476	866	1685	1520	1320	6-Φ28	1880	1720	1520	6-Φ28	964	970	TypeB/TypeB
	110/2	YE2-315S-2	200	150	100	702	641	160	-10	231	400	511	1016	1785	1600	1400	6-Φ28	1980	1814	1614	6-Φ28	1279	1285	TypeB/TypeB
	7.5/4	YE2-132M-4	200	150	100	591	548	160	-10	116	400	396	599	1175	1030	830	6-Φ19	1370	1198	998	6-Φ19	344	350	TypeB/TypeB
	11/4	YE2-160M-4	200	150	100	586	543	160	-10	116	400	396	647	1277	1160	960	6-Φ19	1472	1382	1182	6-Φ19	408	414	TypeB/TypeB
15/4	YE2-160L-4	200	150	100	586	543	160	-10	116	400	396	647	1321	1160	960	6-Φ19	1516	1382	1182	6-Φ19	424	430	TypeB/TypeB	

Model	Power/ Pole	Motor Model	DNs	DNt	L2	b2	b3	a	a2	h	h2	h3	h4	L DSV	L1 DSV	L3 DSV	d DSV	L DSVJ	L1 DSVJ	L3 DSVJ	d DSVJ	DSV Weight (kg)	DSVJ Weight (kg)	DSV/ DSVJType
200-150-250	132/2	YE2-315M-2	200	150	100	702	641	160	-10	231	375	511	1016	1995	1600	1400	6-Φ28	2190	1814	1614	6-Φ28	1424	1430	TypeB/TypeB
	160/2	YE2-315L1-2	200	150	100	702	641	160	-10	231	375	511	1016	1995	1600	1400	6-Φ28	2190	1814	1614	6-Φ28	1528	1534	TypeB/TypeB
	200/2	YE2-315L2-2	200	150	100	702	641	160	-10	231	375	511	1016	1995	1600	1400	6-Φ28	2190	1814	1614	6-Φ28	1568	1574	TypeB/TypeB
	250/2	YE2-355M-2	200	150	100	800	739	160	-10	275	375	555	1210	2185	1800	1600	6-Φ28	2380	2000	1800	8-Φ28	2112	2118	TypeB/TypeC
	15/4	YE2-160L-4	200	150	100	586	543	160	-10	116	375	396	647	1351	1160	960	6-Φ19	1546	1330	1130	6-Φ19	429	435	TypeB/TypeB
	18.5/4	YE2-180M																						

Installation Data

Model	Power/ Pole	Motor Model	DNs	DNt	L2	b2	b3	a	a2	h	h2	h3	h4	L DSV	L1 DSV	L3 DSV	d DSV	L DSVJ	L1 DSVJ	L3 DSVJ	d DSVJ	DSV Weight (kg)	DSVJ Weight (kg)	DSV/ DSVJType
200-150-315	250/2	YE2-355M-2	200	150	100	810	749	160	-10	245	400	560	1215	2325	2030	1830	8-Φ28	2590	2230	2030	8-Φ28	2245	2251	TypeC/TypeC
	315/2	YE2-355L2-2	200	150	100	810	749	160	-10	245	400	560	1215	2325	2030	1830	8-Φ28	2590	2230	2030	8-Φ28	2355	2361	TypeC/TypeC
	355/2	YE2-400M1-2	200	150	100	890	829	160	-10	290	400	605	/	2685	2180	1980	8-Φ28	2950	2450	2250	8-Φ28	3255	3261	TypeC/TypeC
	37/4	YE2-225S-4	200	150	100	610	558	160	-10	156	400	471	796	1645	1438	1238	6-Φ24	1910	1708	1508	6-Φ24	787	797	TypeB/TypeB
	45/4	YE2-225M-4	200	150	100	610	558	160	-10	156	400	471	796	1670	1438	1238	6-Φ24	1935	1708	1508	6-Φ24	803	813	TypeB/TypeB
	55/4	YE2-250M-4	200	150	100	630	569	160	-10	196	400	511	871	1740	1500	1300	6-Φ28	2005	1770	1570	6-Φ28	993	1003	TypeB/TypeB
	75/4	YE2-280S-4	200	150	100	680	619	160	-10	196	400	511	901	1805	1660	1460	6-Φ28	2070	1920	1720	6-Φ28	1079	1089	TypeB/TypeB
	90/4	YE2-280M-4	200	150	100	680	619	160	-10	196	400	511	901	1855	1660	1460	6-Φ28	2120	1920	1720	6-Φ28	1199	1209	TypeB/TypeB

Model	Power/ Pole	Motor Model	DNs	DNt	L2	b2	b3	a	a2	h	h2	h3	h4	L DSV	L1 DSV	L3 DSV	d DSV	L DSVJ	L1 DSVJ	L3 DSVJ	d DSVJ	DSV Weight (kg)	DSVJ Weight (kg)	DSV/ DSVJType
200-150-400	55/4	YE2-250M-4	200	150	100	630	569	160	-10	196	450	511	871	1740	1500	1300	6-Φ28	2005	1770	1570	6-Φ28	1047	1057	TypeB/TypeB
	75/4	YE2-280S-4	200	150	100	680	619	160	-10	196	450	511	901	1805	1660	1460	6-Φ28	2070	1920	1720	6-Φ28	1132	1142	TypeB/TypeB
	90/4	YE2-280M-4	200	150	100	680	619	160	-10	196	450	511	901	1855	1660	1460	6-Φ28	2120	1920	1720	6-Φ28	1253	1263	TypeB/TypeB
	110/4	YE2-315S-4	200	150	100	690	629	160	-10	196	450	511	1016	1955	1850	1650	6-Φ28	2220	2056	1856	8-Φ28	1518	1528	TypeB/TypeC
	132/4	YE2-315M-4	200	150	100	690	629	160	-10	196	450	511	1016	2135	1850	1650	6-Φ28	2400	2056	1856	8-Φ28	1630	1640	TypeB/TypeC
	160/4	YE2-315L1-4	200	150	100	690	629	160	-10	196	450	511	1016	2135	1850	1650	6-Φ28	2400	2056	1856	8-Φ28	1721	1731	TypeB/TypeC

Model	Power/ Pole	Motor Model	DNs	DNt	L2	b2	b3	a	a2	h	h2	h3	h4	L DSV	L1 DSV	L3 DSV	d DSV	L DSVJ	L1 DSVJ	L3 DSVJ	d DSVJ	DSV Weight (kg)	DSVJ Weight (kg)	DSV/ DSVJType
200-150-500	132/4	YE2-315M-4	200	150	100	690	629	180	-10	196	500	596	1101	2155	1850	1650	6-Φ28	2420	2056	1856	8-Φ28	1879	1889	TypeB/TypeC
	160/4	YE2-315L1-4	200	150	100	690	629	180	-10	196	500	596	1101	2155	1850	1650	6-Φ28	2420	2056	1856	8-Φ28	1973	1983	TypeB/TypeC
	200/4	YE2-315L2-4	200	150	100	690	629	180	-10	196	500	596	1101	2155	1850	1650	6-Φ28	2420	2056	1856	8-Φ28	2129	2139	TypeB/TypeC
	250/4	YE2-355M-4	200	150	100	800	739	180	-10	196	500	596	1251	2375	1980	1780	6-Φ28	2640	2180	1980	8-Φ28	2245	2251	TypeB/TypeC

Installation Data

Model	Power/ Pole	Motor Model	DNs	DNt	L2	b2	b3	a	a2	h	h2	h3	h4	L DSV	L1 DSV	L3 DSV	d DSV	L DSVJ	L1 DSVJ	L3 DSVJ	d DSVJ	DSV Weight (kg)	DSVJ Weight (kg)	DSV/ DSVJType
250-200-400	37/4	YE2-225S-4	250	200	100	660	608	170	-10	156	400	556	881	1674	1460	1260	6-Φ24	1939	1730	1530	6-Φ24	896	906	TypeB/TypeB
	45/4	YE2-225M-4	250	200	100	660	608	170	-10	156	400	556	881	1699	1460	1260	6-Φ24	1964	1730	1530	6-Φ24	912	922	TypeB/TypeB
	55/4	YE2-250M-4	250	200	100	680	619	170	-10	196	400	596	956	1769	1530	1330	6-Φ28	2034	1800	1600	6-Φ28	1106	1116	TypeB/TypeB
	75/4	YE2-280S-4	250	200	100	690	629	170	-10	196	400	596	986	1834	1660	1460	6-Φ28	2099	1920	1720	6-Φ28	1230	1240	TypeB/TypeB
	90/4	YE2-280M-4	250	200	100	690	629	170	-10	196	400	596	986	1884	1660	1460	6-Φ28	2149	1920	1720	6-Φ28	1350	1360	TypeB/TypeB
	110/4	YE2-315S-4	250	200	100	690	629	170	-10	196	400	596	1101	1984	1850	1650	6-Φ28	2249	2056	1856	8-Φ28	1611	1621	TypeB/TypeC
	132/4	YE2-315M-4	250	200	100	690	629	170	-10	196	400	596	1101	2164	1850	1650	6-Φ28	2429	2056	1856	8-Φ28	1781	1791	TypeB/TypeC

Model	Power/ Pole	Motor Model	DNs	DNt	L2	b2	b3	a	a2	h	h2	h3	h4	L DSV	L1 DSV	L3 DSV	d DSV	L DSVJ	L1 DSVJ	L3 DSVJ	d DSVJ	DSV Weight (kg)	DSVJ Weight (kg)	DSV/ DSVJType
250-200-450	75/4	YE2-280S-4	250	200	100	690	629	150	-10	196	450	596	986	1814	1660	1460	6-Φ28	2079	1920	1720	6-Φ28	1245	1255	TypeB/TypeB
	90/4	YE2-280M-4	250	200	100	690	629	150	-10	196	450	596	986	1864	1660	1460	6-Φ28	2129	1920	1720	6-Φ28	1365	1375	TypeB/TypeB
	110/4	YE2-315S-4	250	200	100	690	629	150	-10	196	450	596	1101	1964	1850	1650	6-Φ28	2229	2056	1856	8-Φ28	1626	1636	TypeB/TypeC
	132/4	YE2-315M-4	250	200	100	690	629	150	-10	196	450	596	1101	2144	1850	1650	6-Φ28	2409	2056	1856	8-Φ28	1796	1806	TypeB/TypeC
	160/4	YE2-315L1-4	250	200	100	690	629	150	-10	196	450	596	1101	2144	1850	1650	6-Φ28	2409	2056	1856	8-Φ28	1858	1868	TypeB/TypeC

Model	Power/ Pole	Motor Model	DNs	DNt	L2	b2	b3	a	a2	h	h2	h3	h4	L DSV	L1 DSV	L3 DSV	d DSV	L DSVJ	L1 DSVJ	L3 DSVJ	d DSVJ	DSV Weight (kg)	DSVJ Weight (kg)	DSV/ DSVJType
300-250-350	37/4	YE2-225S-4	300	250	100	660	608	175	-10	156	400	606	931	1719	1504	1304	6-Φ24	1984	1780	1580	6-Φ24	996	1006	TypeB/TypeB
	45/4	YE2-225M-4	300	250	100	660	608	175	-10	156	400	606	931	1744	1504	1304	6-Φ24	2009	1780	1580	6-Φ24	1017	1027	TypeB/TypeB
	55/4	YE2-250M-4	300	250	100	780	719	175	-10	196	400	646	1006	1814	1568	1368	6-Φ28	2079	1820	1620	6-Φ28	1225	1235	TypeB/TypeB
	75/4	YE2-280S-4	300	250	100	780	719	175	-10	196	400	646	1036	1879	1700	1500	6-Φ28	2144	1920	1720	6-Φ28	1315	1325	TypeB/TypeB
	90/4	YE2-280M-4	300	250	100	780	719	175	-10	196	400	646	1036	1929	1700	1500	6-Φ28	2194	1920	1720	6-Φ28	1471	1481	TypeB/TypeB

Installation Data

Model	Power/ Pole	Motor Model	DNs	DNt	L2	b2	b3	a	a2	h	h2	h3	h4	L DSV	L1 DSV	L3 DSV	d DSV	L DSVJ	L1 DSVJ	L3 DSVJ	d DSVJ	DSV Weight (kg)	DSVJ Weight (kg)	DSV/ DSVJType
300-250-400	45/4	YE2-225M-4	300	250	100	660	608	160	-10	156	500	606	931	1702	1504	1304	6-Φ24	1967	1780	1580	6-Φ24	968	978	TypeB/TypeB
	55/4	YE2-250M-4	300	250	100	780	719	160	-10	196	500	646	1006	1772	1568	1368	6-Φ28	2037	1820	1620	6-Φ28	1225	1235	TypeB/TypeB
	75/4	YE2-280S-4	300	250	100	780	719	160	-10	196	500	646	1036	1837	1700	1500	6-Φ28	2102	1920	1720	6-Φ28	1302	1312	TypeB/TypeB
	90/4	YE2-280M-4	300	250	100	780	719	160	-10	196	500	646	1036	1887	1700	1500	6-Φ28	2152	1920	1720	6-Φ28	1422	1432	TypeB/TypeB
	110/4	YE2-315S-4	300	250	100	780	719	160	-10	196	500	646	1151	1987	1900	1700	6-Φ28	2252	2110	1910	8-Φ28	1680	1690	TypeB/TypeC
	132/4	YE2-315M-4	300	250	100	780	719	160	-10	196	500	646	1151	2167	1900	1700	6-Φ28	2432	2110	1910	8-Φ28	1844	1854	TypeB/TypeC
	160/4	YE2-315L1-4	300	250	100	780	719	160	-10	196	500	646	1151	2167	1900	1700	6-Φ28	2432	2110	1910	8-Φ28	1906	1916	TypeB/TypeC

Model	Power/ Pole	Motor Model	DNs	DNt	L2	b2	b3	a	a2	h	h2	h3	h4	L DSV	L1 DSV	L3 DSV	d DSV	L DSVJ	L1 DSVJ	L3 DSVJ	d DSVJ	DSV Weight (kg)	DSVJ Weight (kg)	DSV/ DSVJType
300-250-450	75/4	YE2-280S-4	300	250	100	780	719	165	-10	196	500	646	1036	1825	1700	1500	6-Φ28	2090	1920	1720	6-Φ28	1379	1389	TypeB/TypeB
	90/4	YE2-280M-4	300	250	100	780	719	165	-10	196	500	646	1036	1875	1700	1500	6-Φ28	2140	1920	1720	6-Φ28	1499	1509	TypeB/TypeB
	110/4	YE2-315S-4	300	250	100	780	719	165	-10	196	500	646	1151	1975	1900	1700	6-Φ28	2240	2110	1910	8-Φ28	1757	1767	TypeB/TypeC
	132/4	YE2-315M-4	300	250	100	780	719	165	-10	196	500	646	1151	2155	1900	1700	6-Φ28	2420	2110	1910	8-Φ28	1921	1931	TypeB/TypeC
	160/4	YE2-315L1-4	300	250	100	780	719	165	-10	196	500	646	1151	2155	1900	1700	6-Φ28	2420	2110	1910	8-Φ28	1983	1993	TypeB/TypeC
200/4	YE2-315L2-4	300	250	100	780	719	165	-10	196	500	646	1151	2155	1900	1700	6-Φ28	2420	2110	1910	8-Φ28	2143	2153	TypeB/TypeC	

Model	Power/ Pole	Motor Model	DNs	DNt	L2	b2	b3	a	a2	h	h2	h3	h4	L DSV	L1 DSV	L3 DSV	d DSV	L DSVJ	L1 DSVJ	L3 DSVJ	d DSVJ	DSV Weight (kg)	DSVJ Weight (kg)	DSV/ DSVJType
300-250-500	160/4	YE2-315L1-4	300	250	100	780	719	165	-10	196	500	646	1151	2163	1900	1700	6-Φ28	2428	2110	1910	8-Φ28	2124	2134	TypeB/TypeC
	200/4	YE2-315L2-4	300	250	100	780	719	165	-10	196	500	646	1151	2163	1900	1700	6-Φ28	2428	2110	1910	8-Φ28	2284	2294	TypeB/TypeC
	250/4	YE2-355M-4	300	250	100	800	739	165	-10	196	500	646	1301	2383	2015	1815	8-Φ28	2648	2204	2004	8-Φ28	2334	2344	TypeC/TypeC
	315/4	YE2-355L2-4	300	250	100	800	739	165	-10	196	500	646	1301	2383	2015	1815	8-Φ28	2648	2204	2004	8-Φ28	2564	2574	TypeC/TypeC

Performance Curve

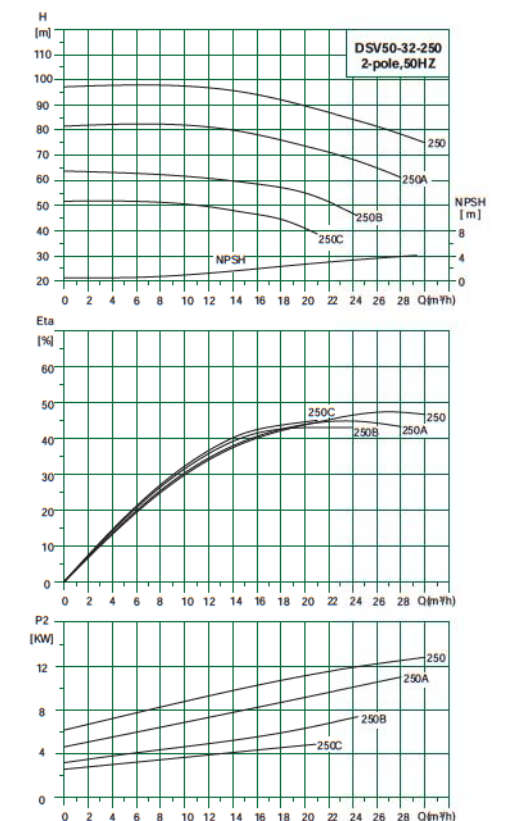
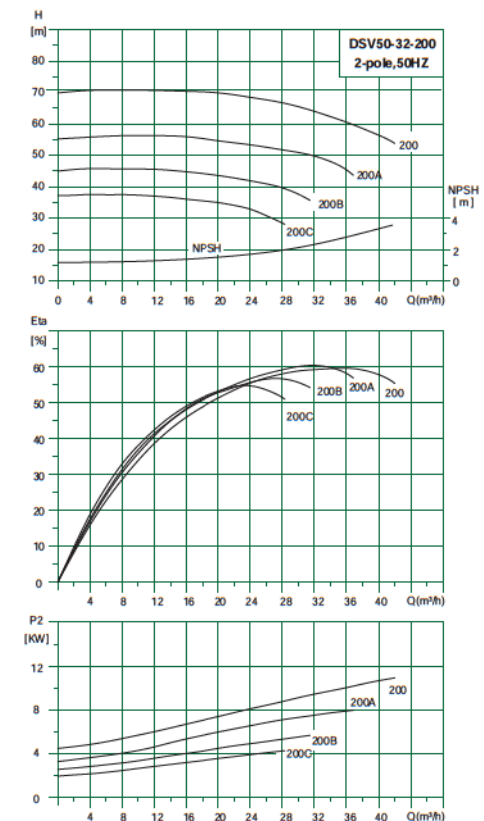
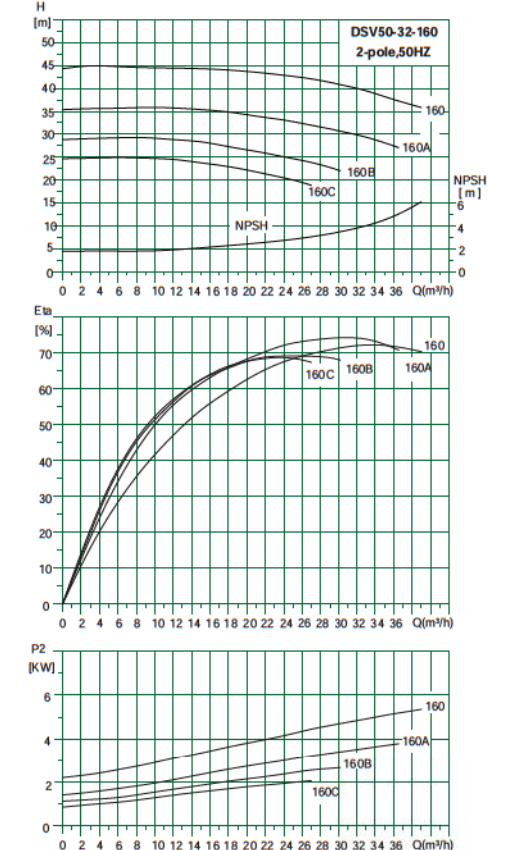
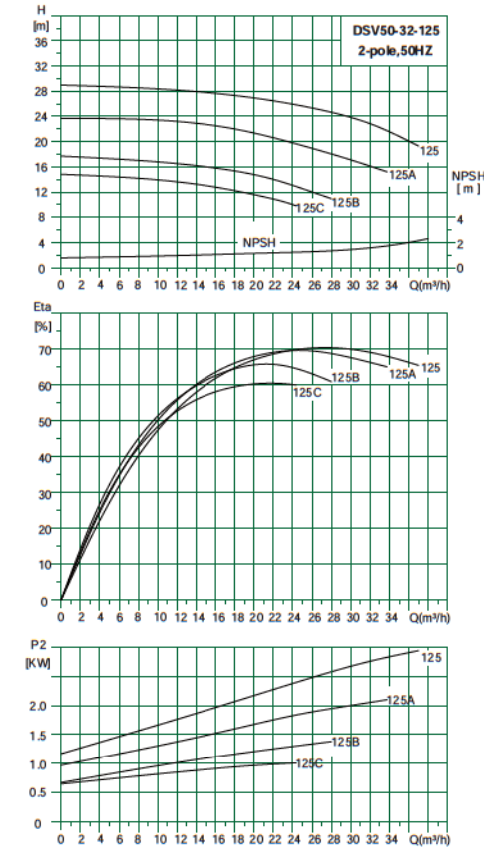

Performance Curve

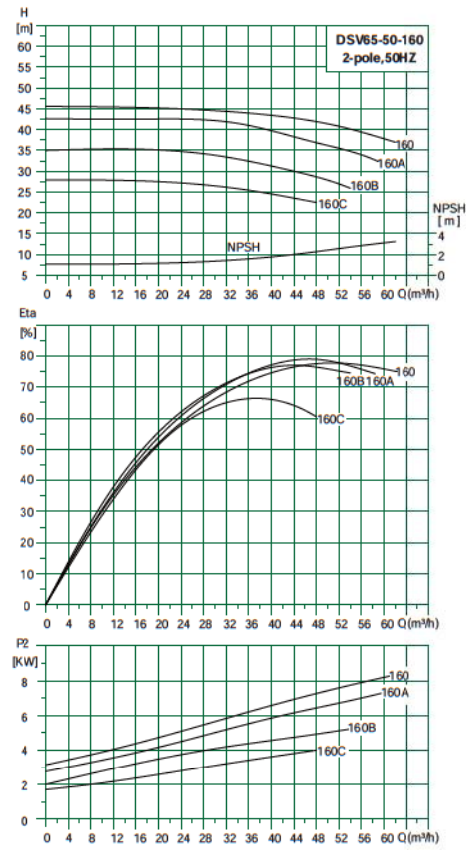
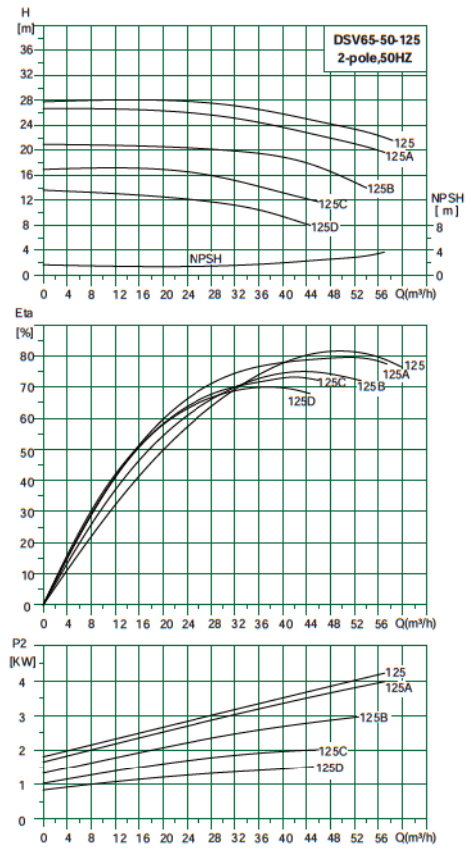

Performance Curve

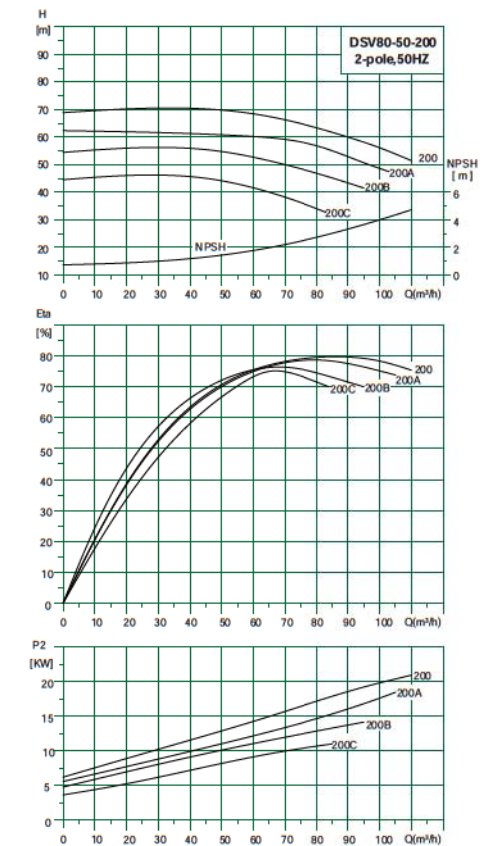
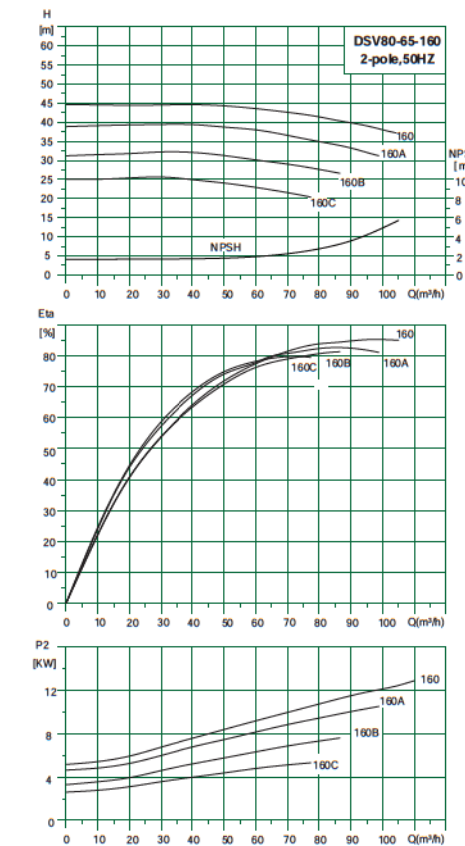
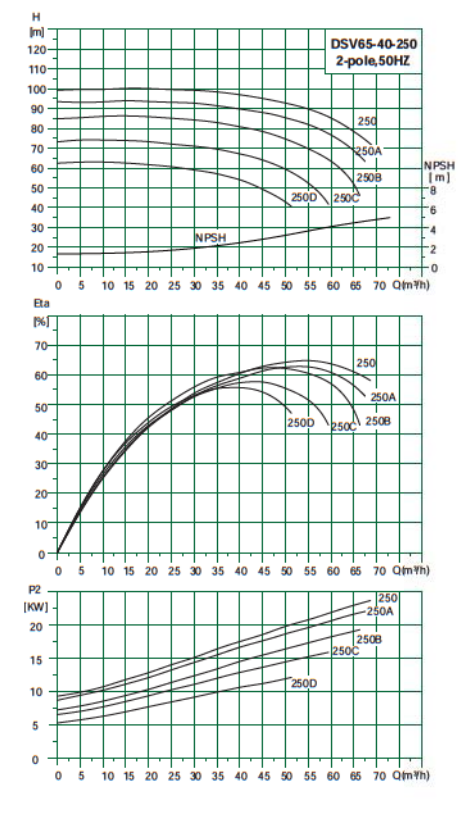
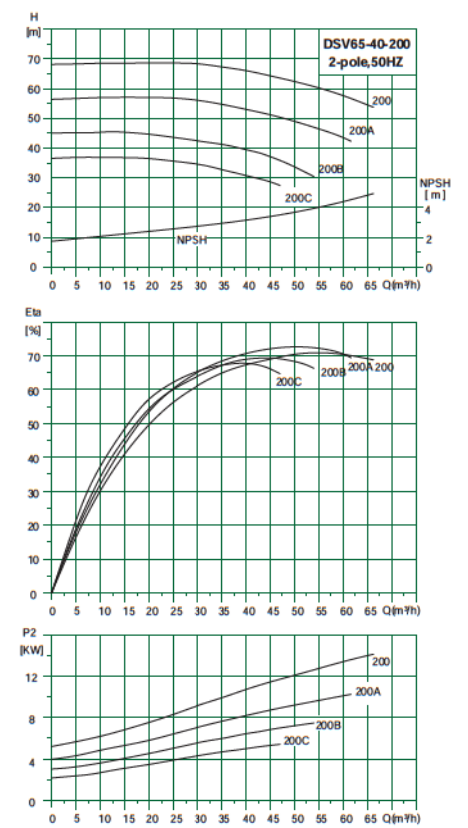
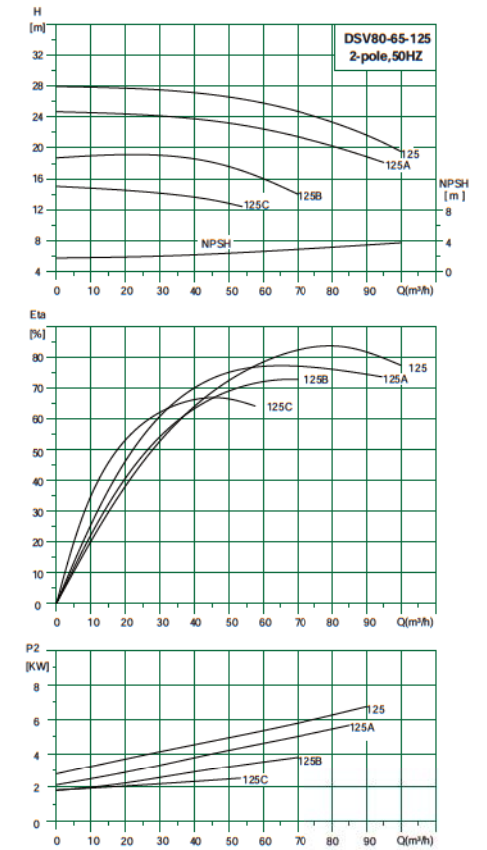
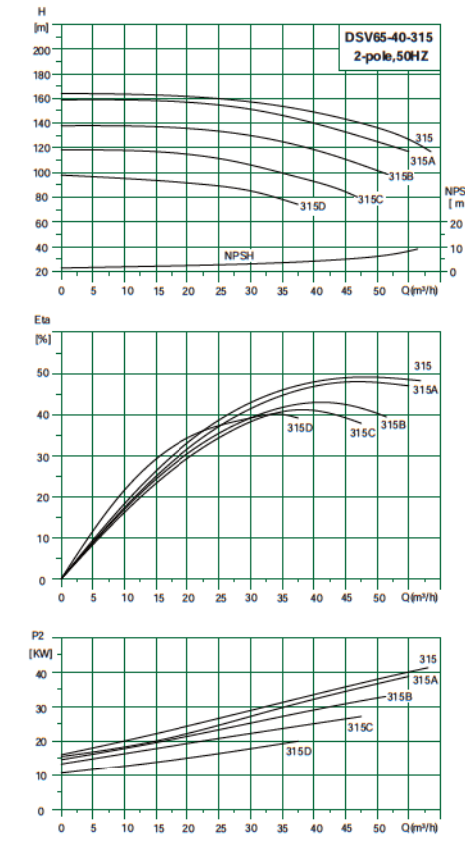

Performance Curve

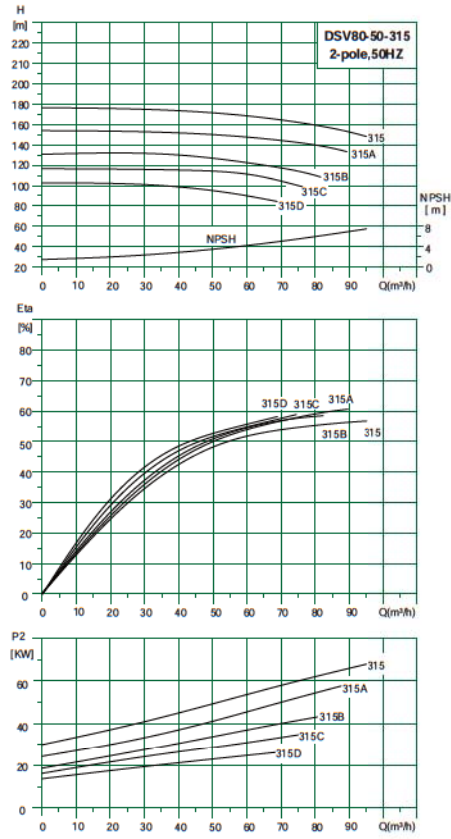
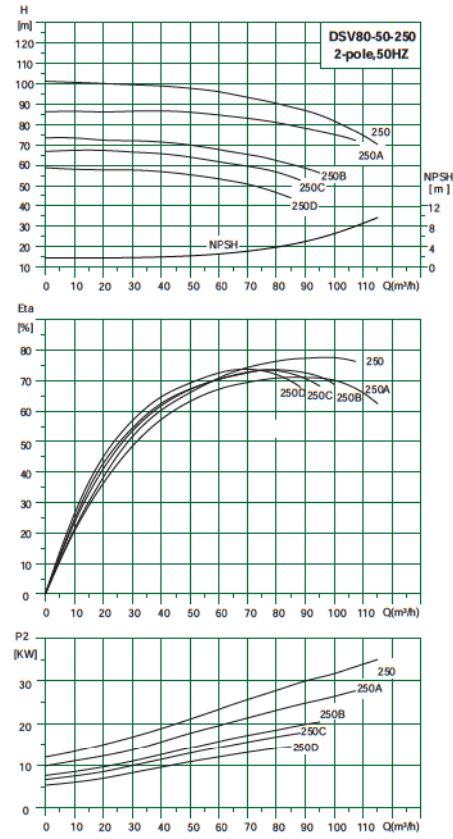

Performance Curve

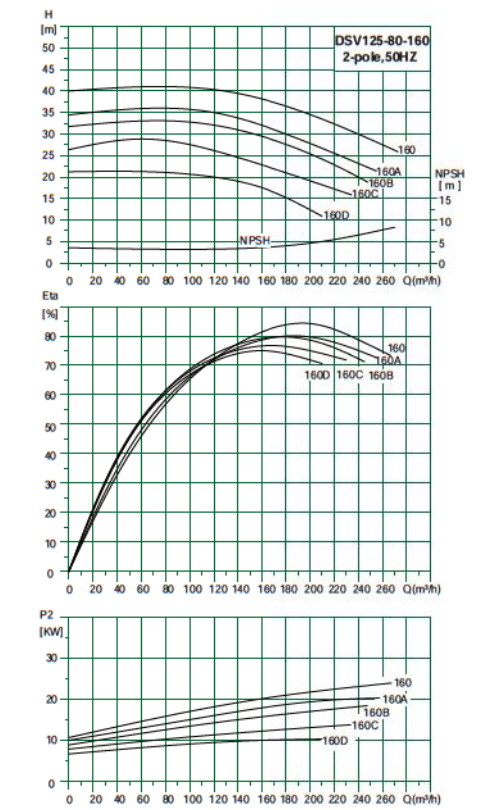
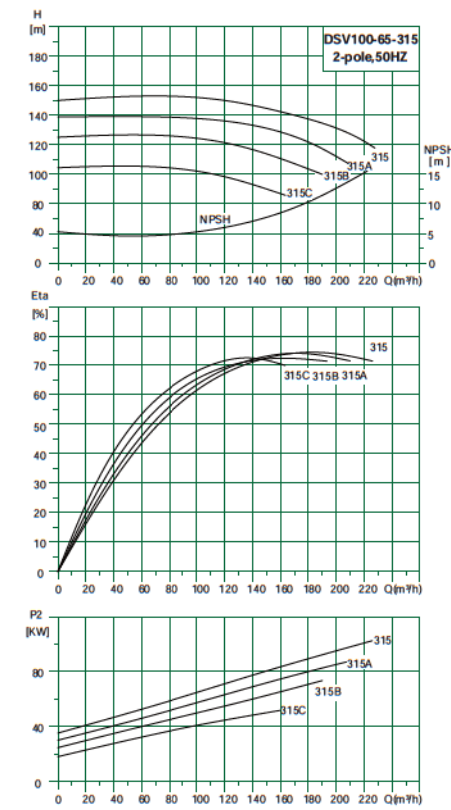
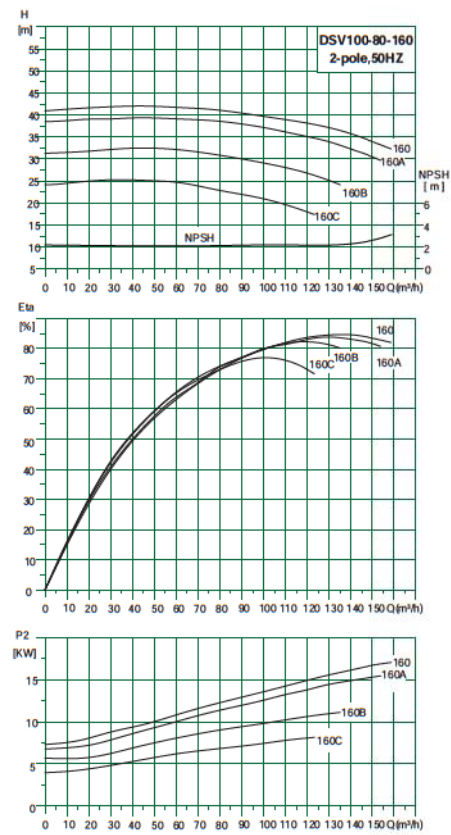
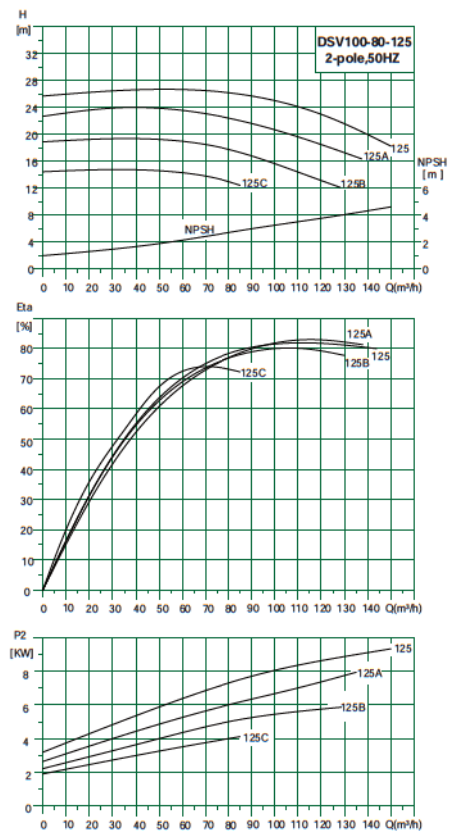
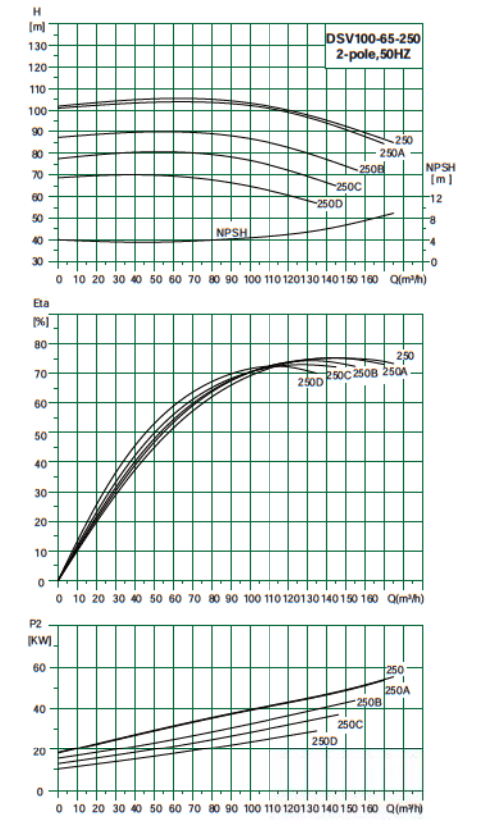
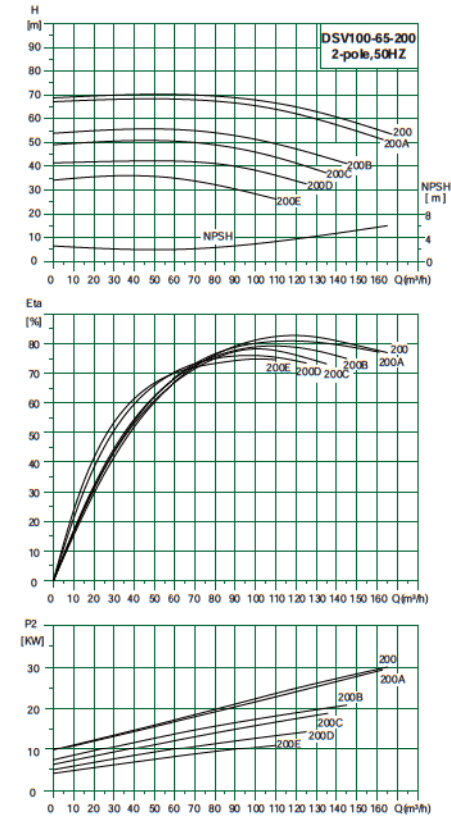

Performance Curve

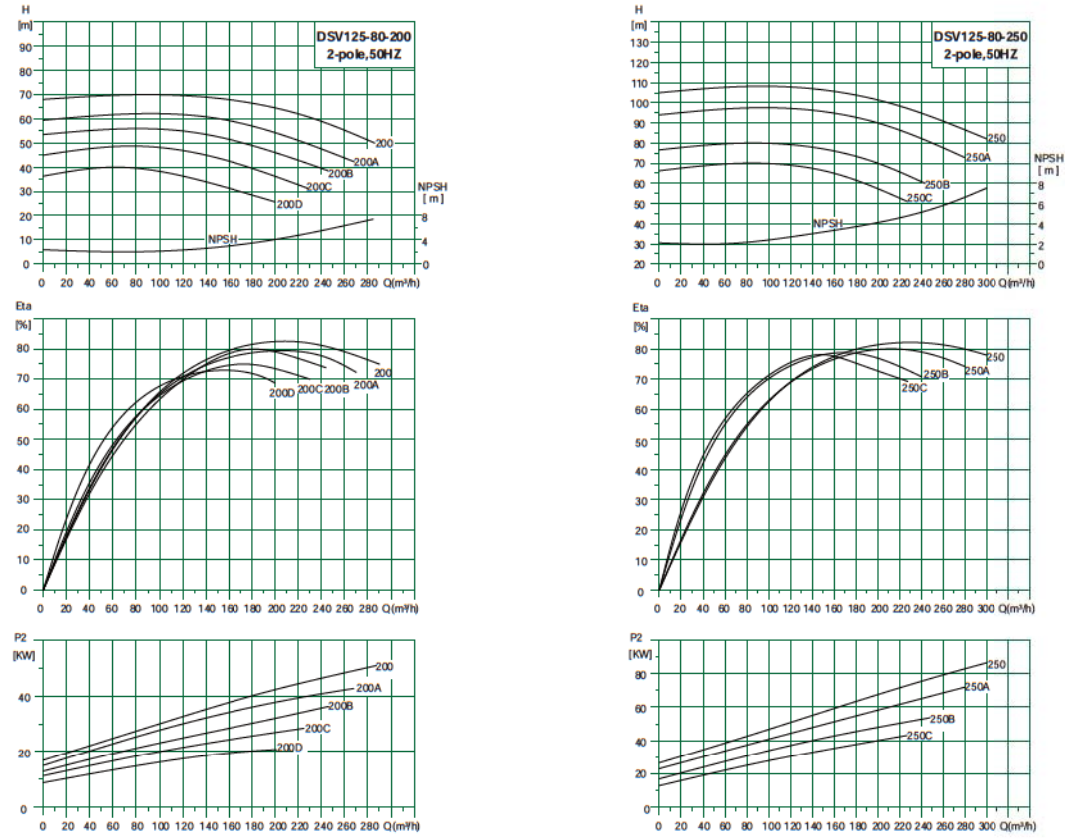

Performance Curve

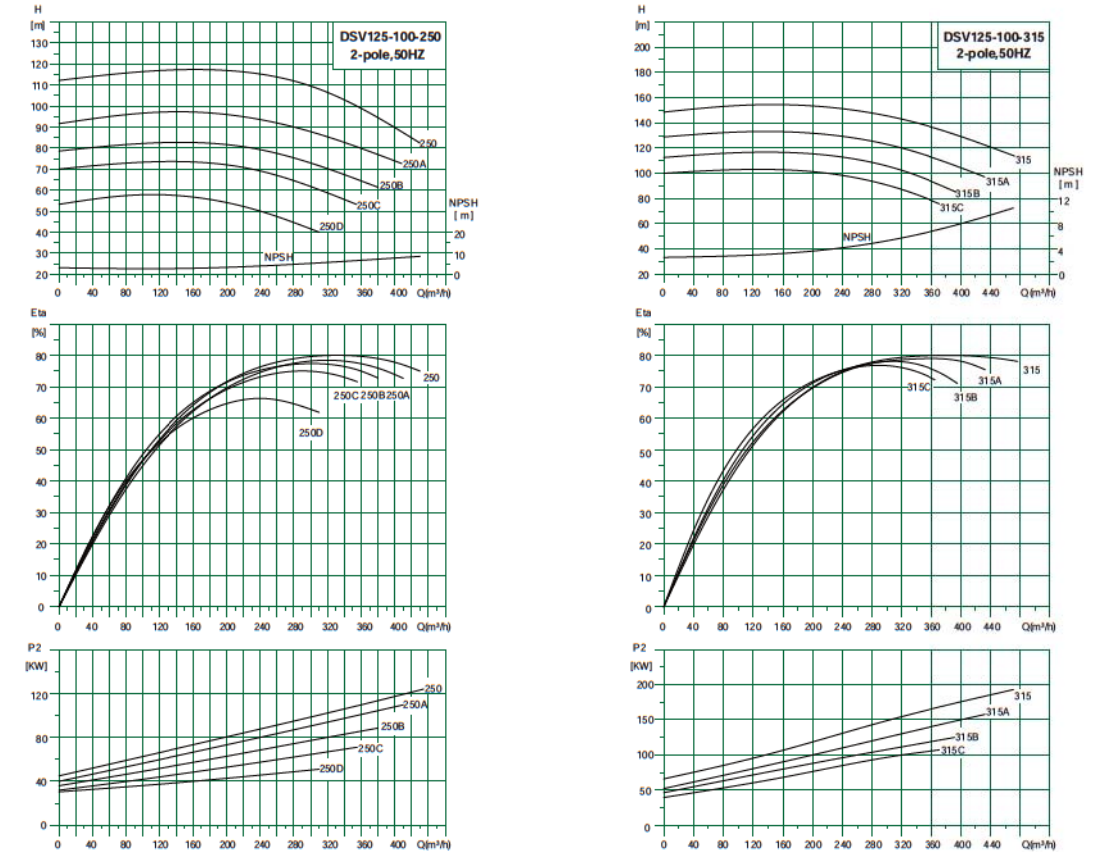
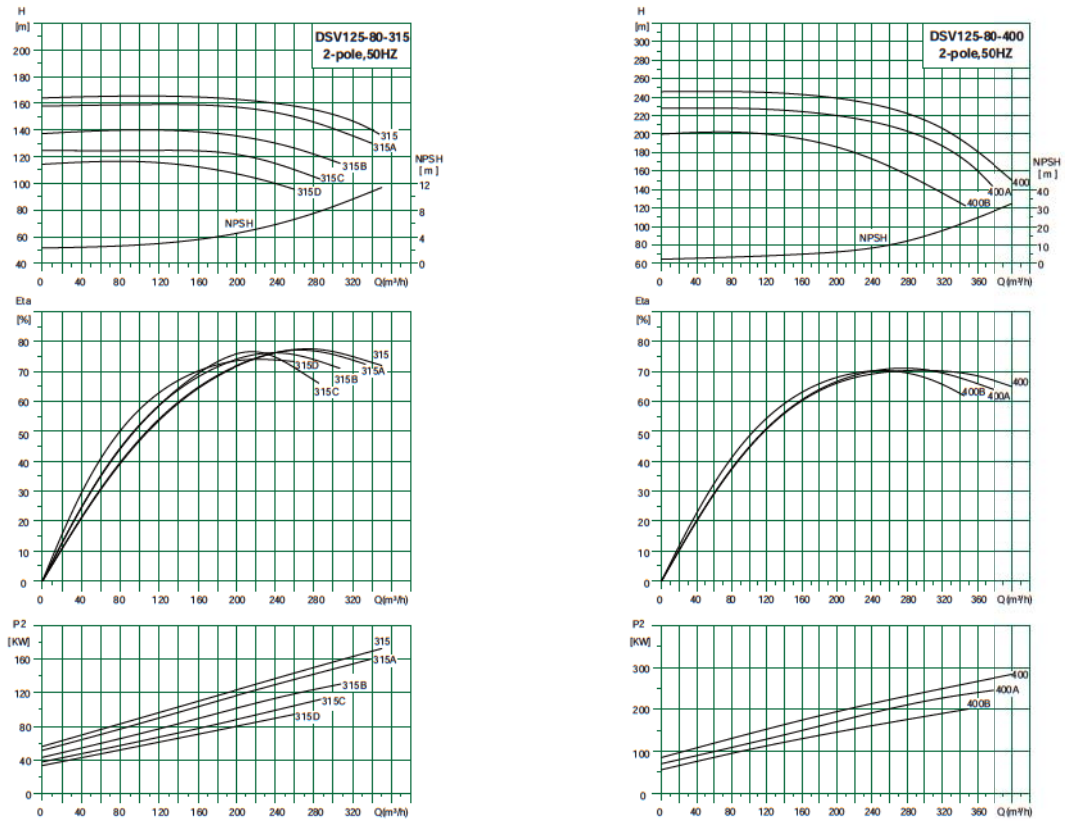
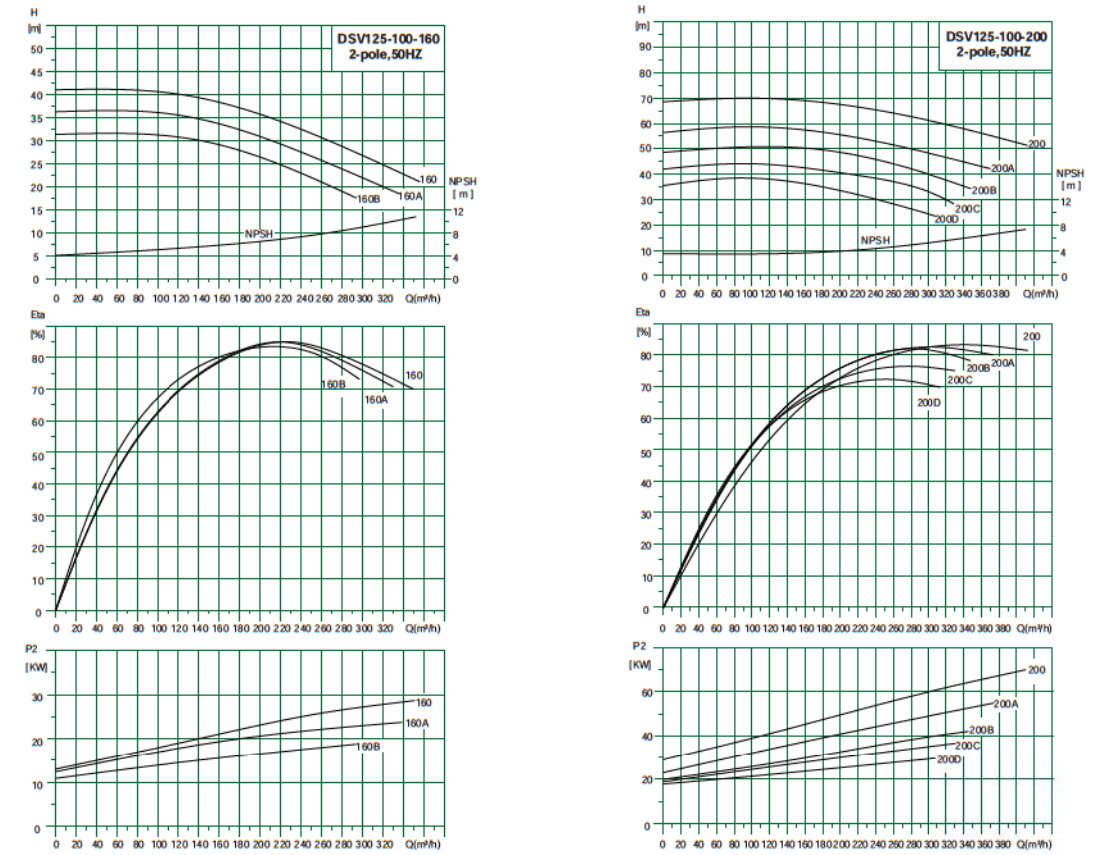

Performance Curve

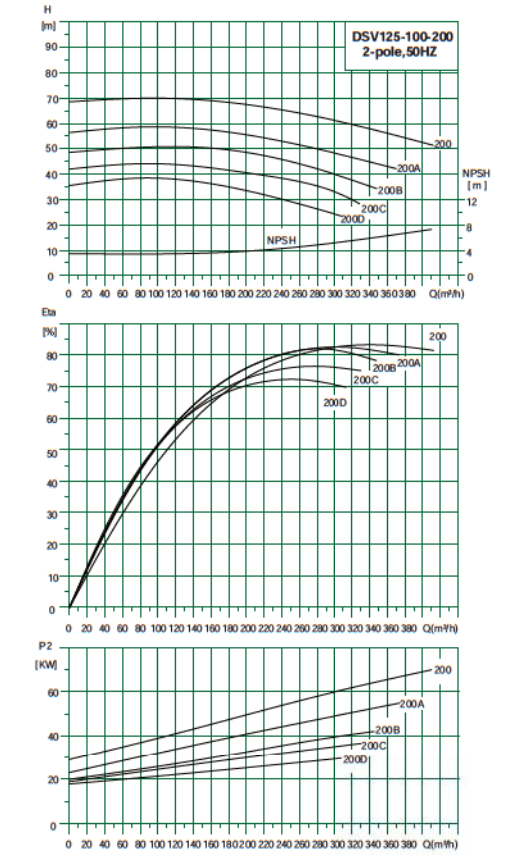

Performance Curve

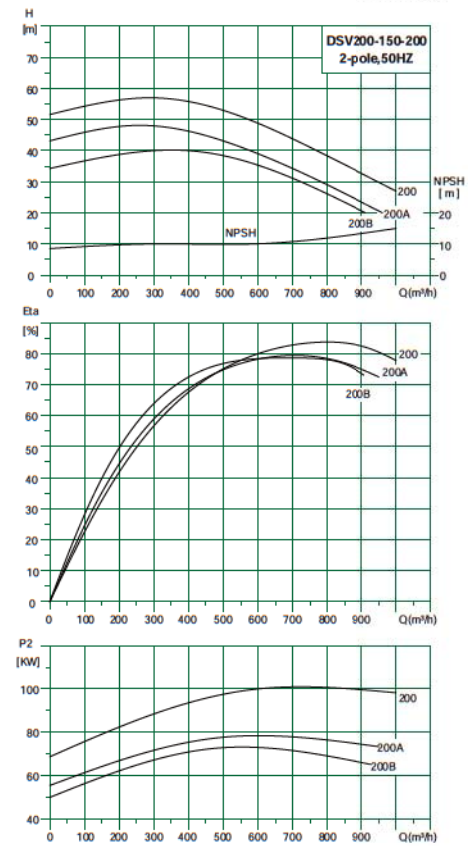
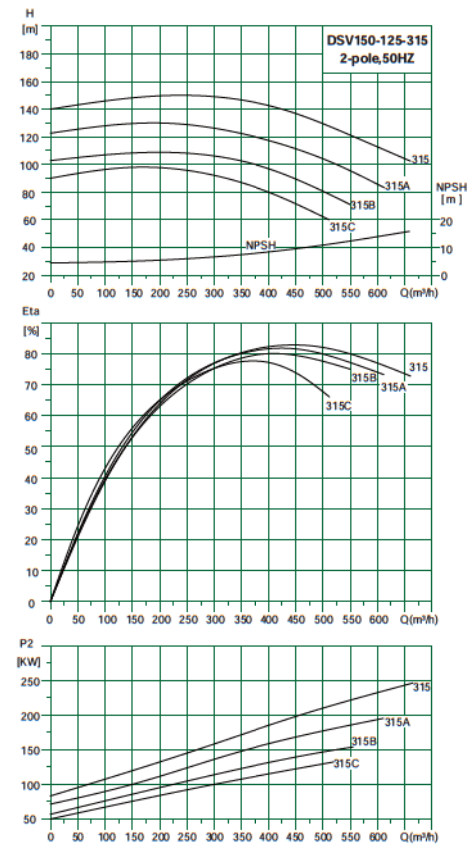
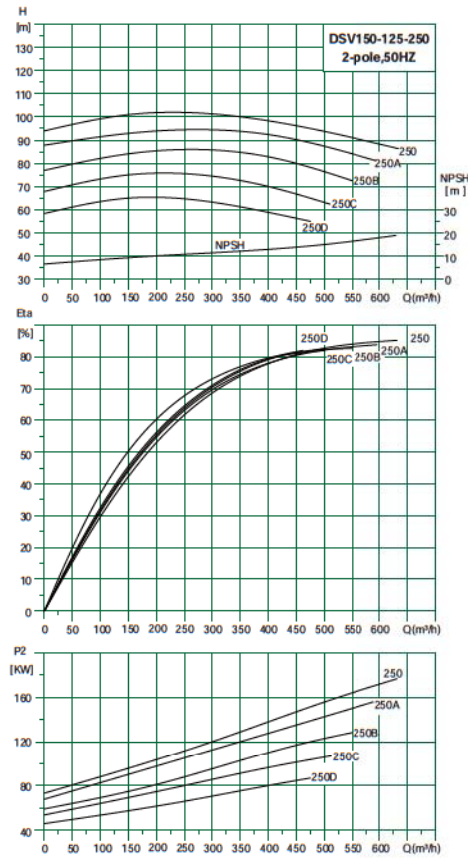
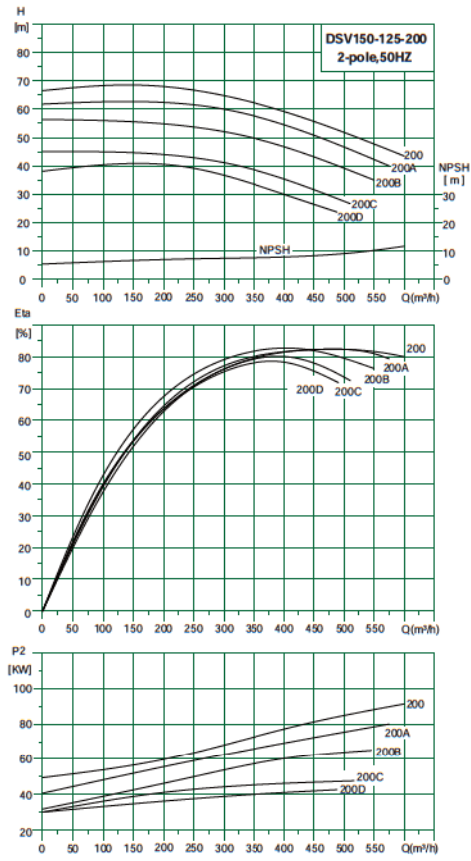

Performance Curve

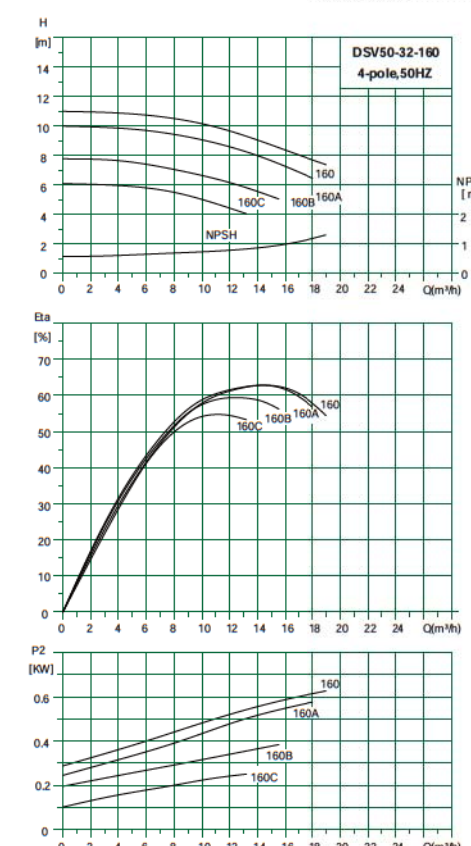
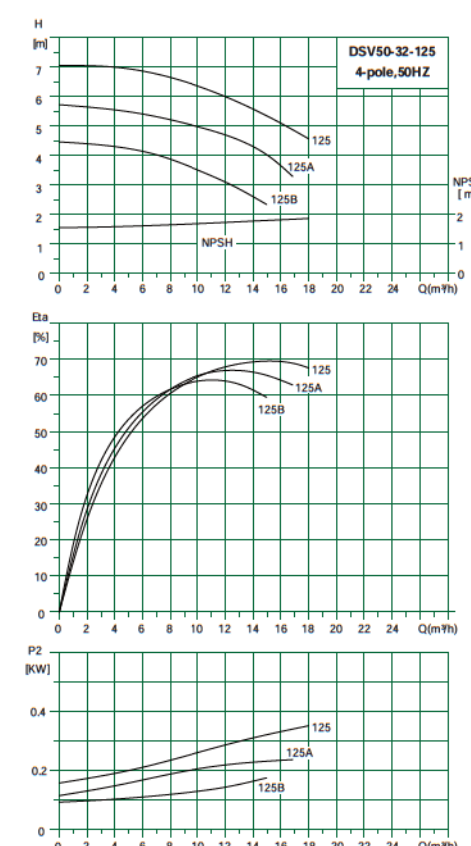
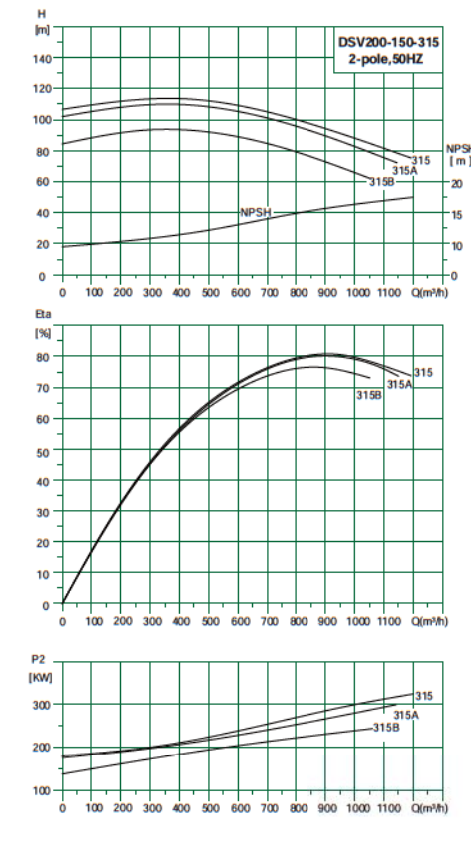
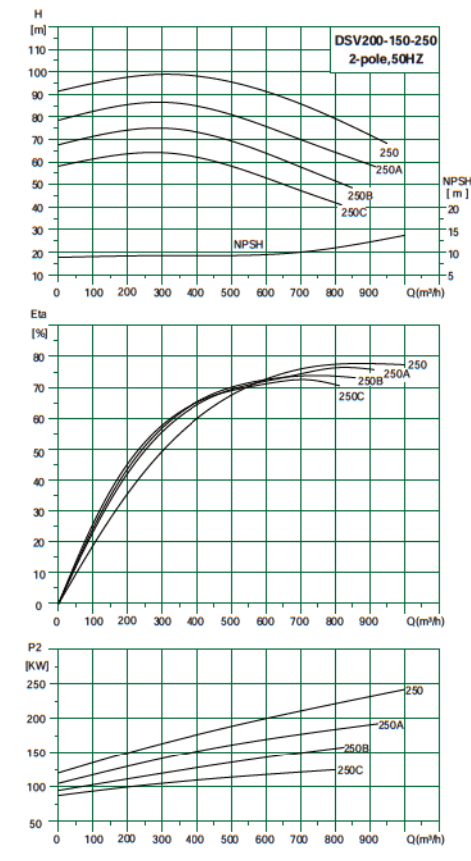

Performance Curve

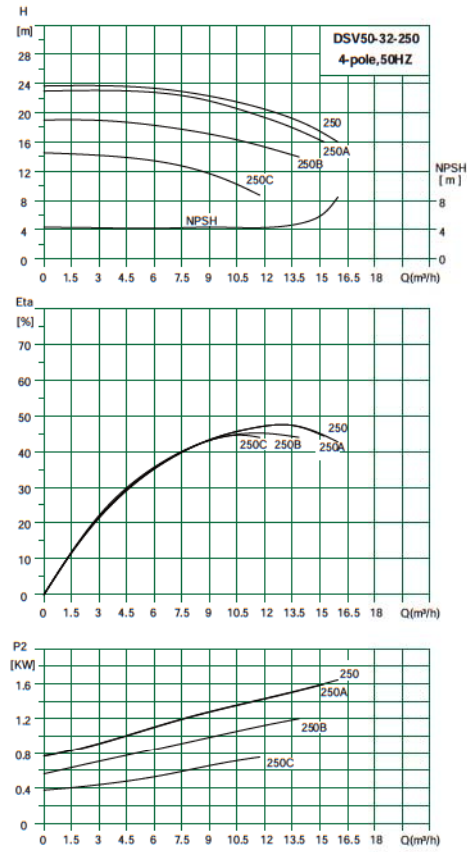
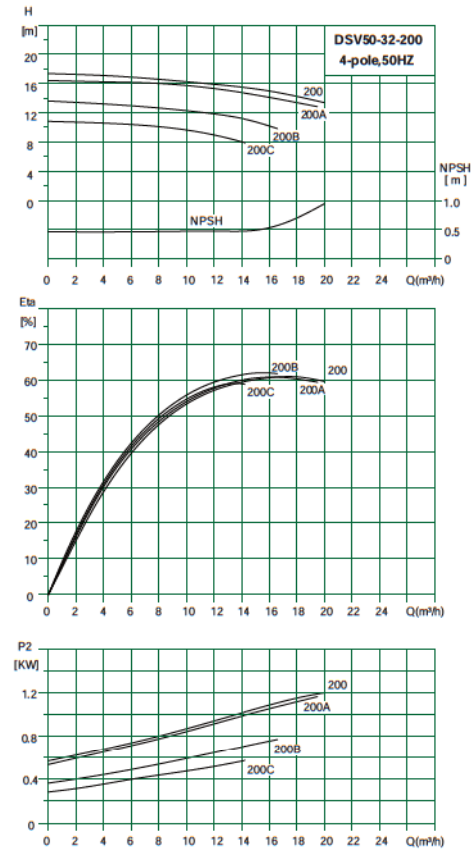

Performance Curve

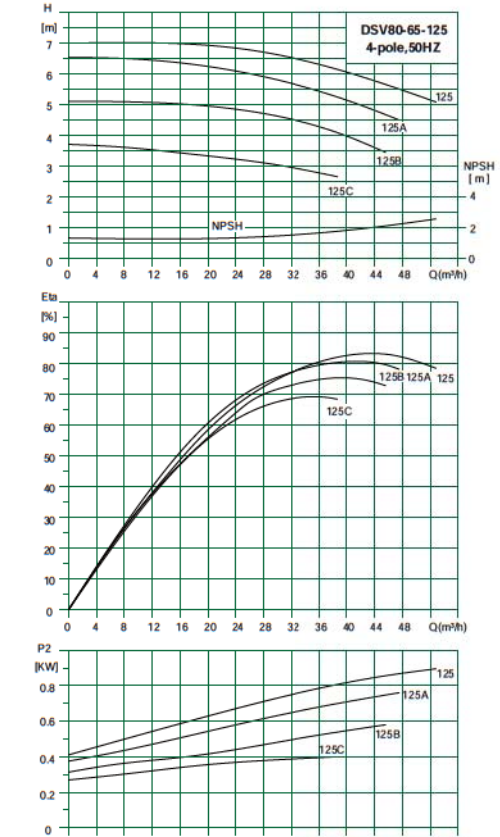
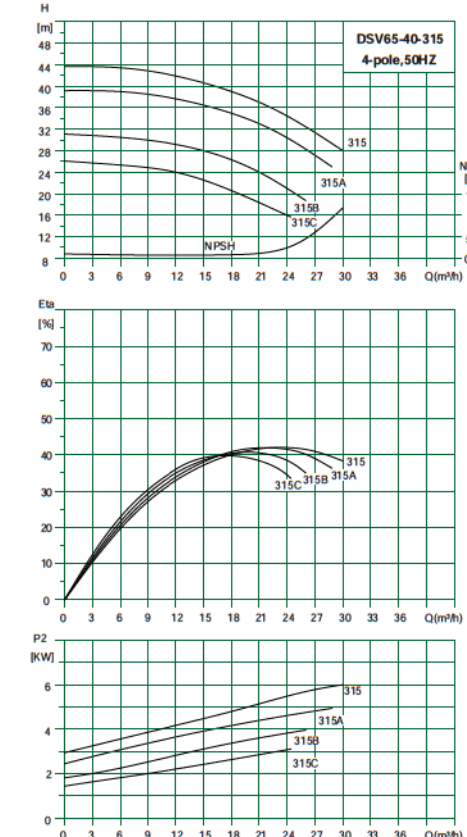
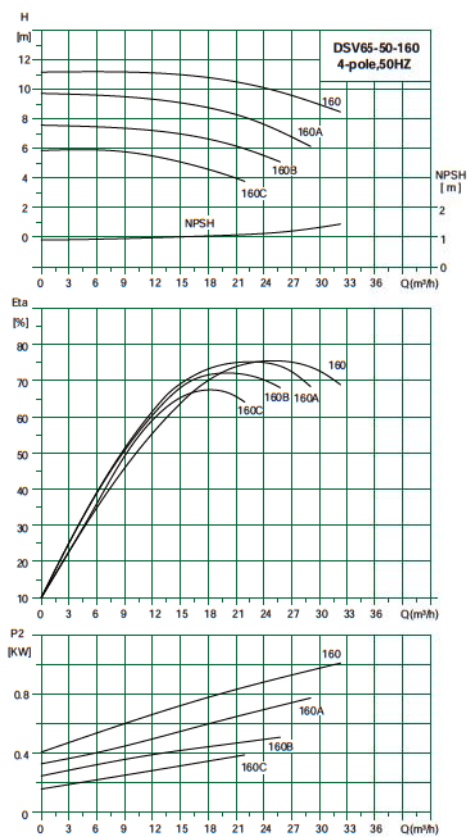
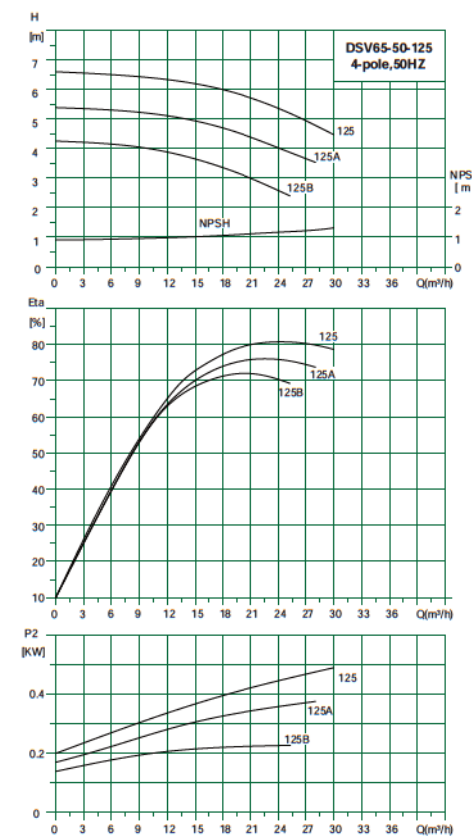
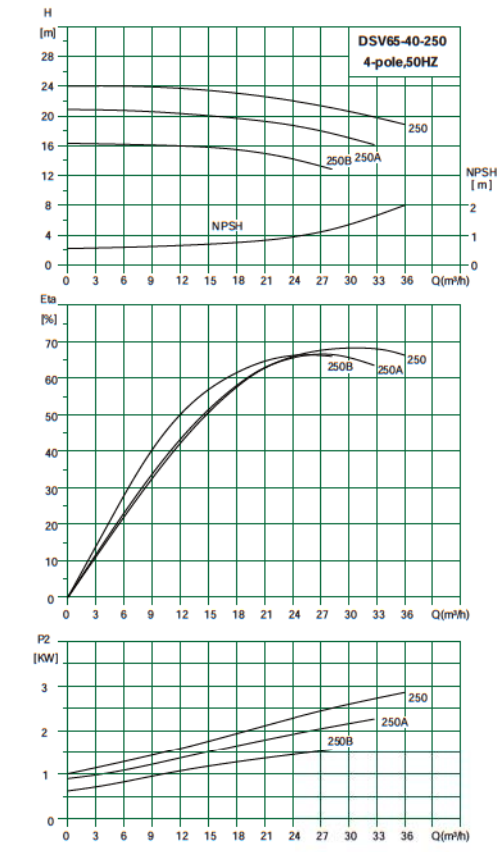
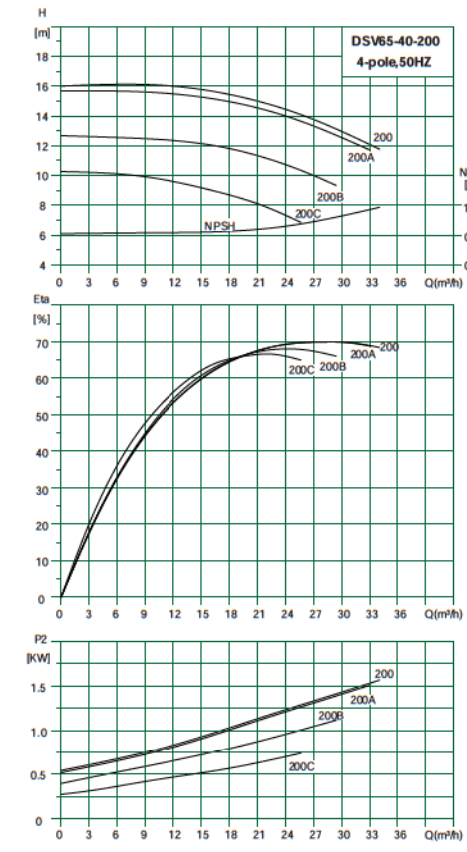

Performance Curve

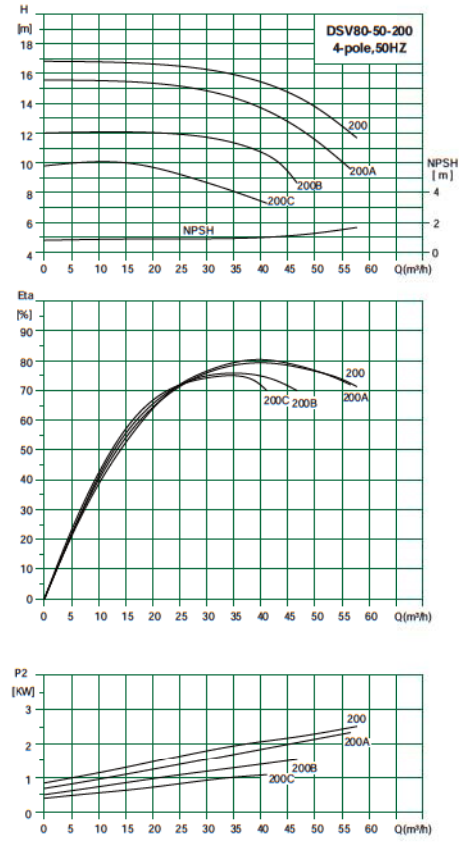
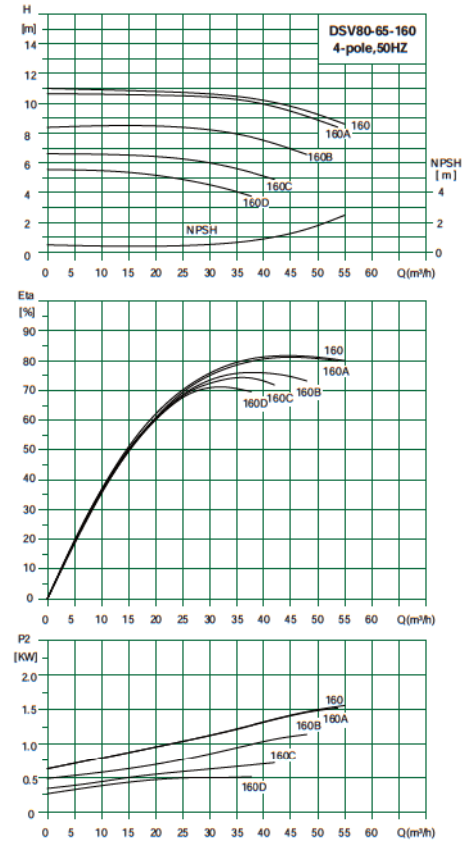

Performance Curve

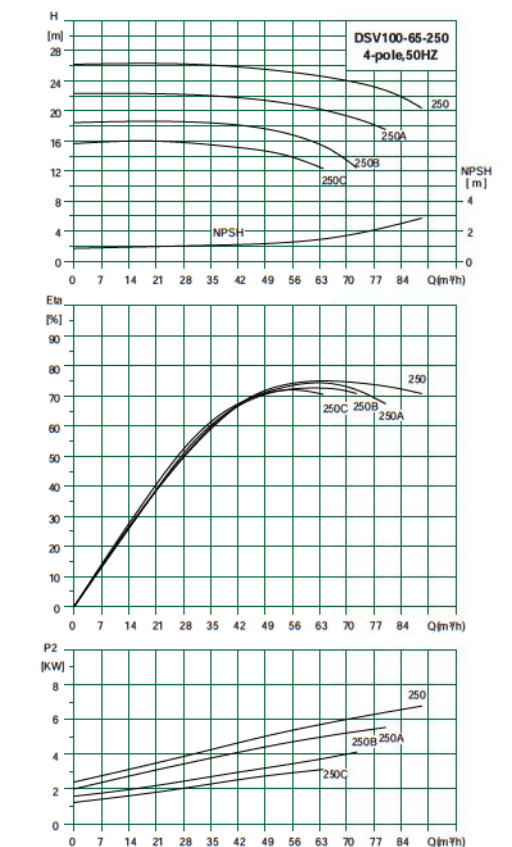
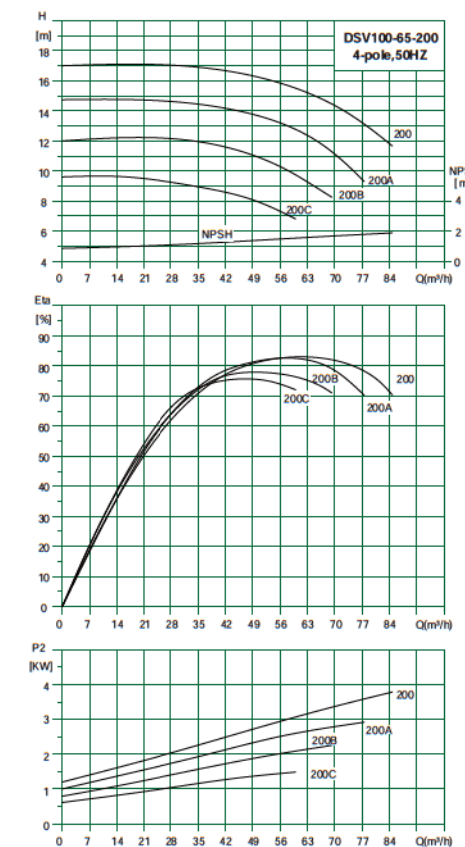
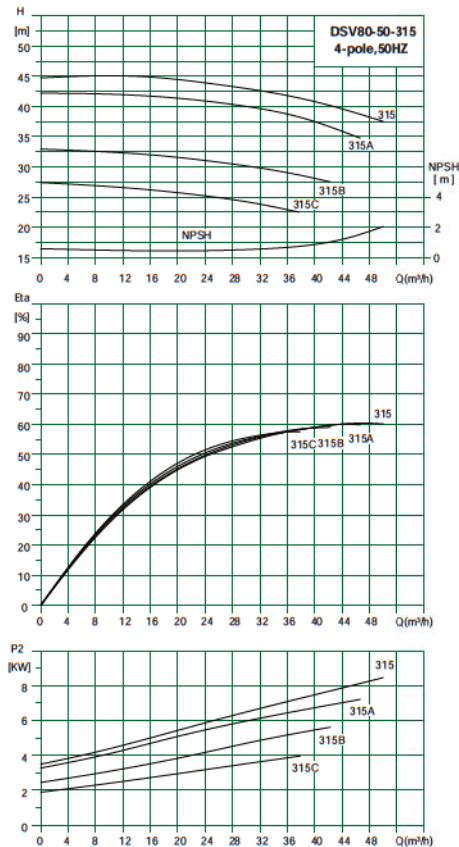
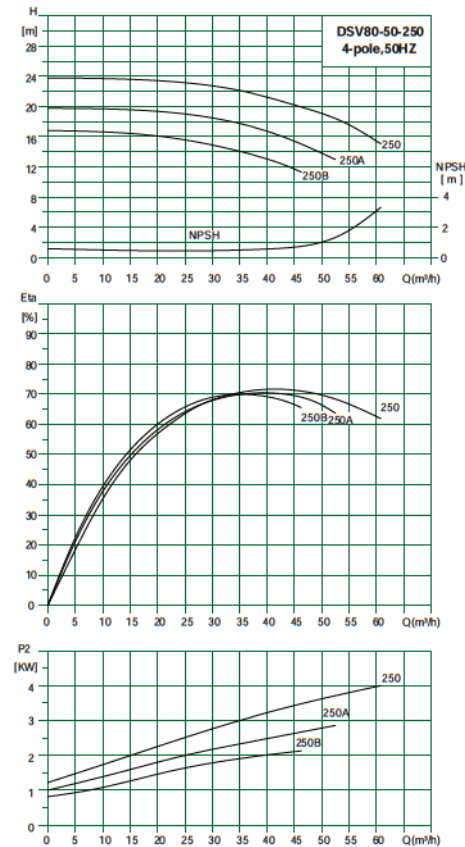
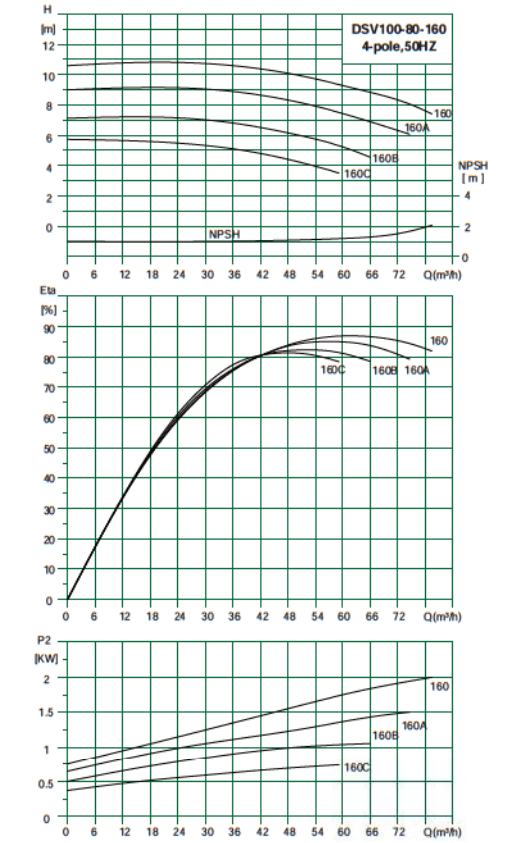
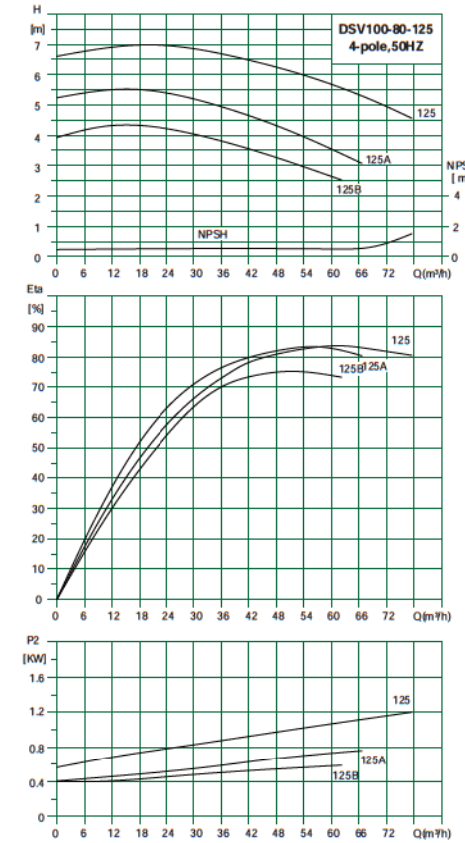

Performance Curve

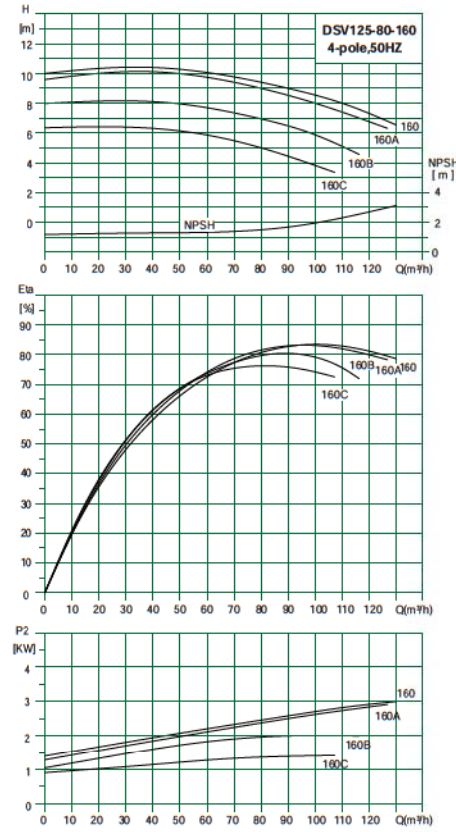
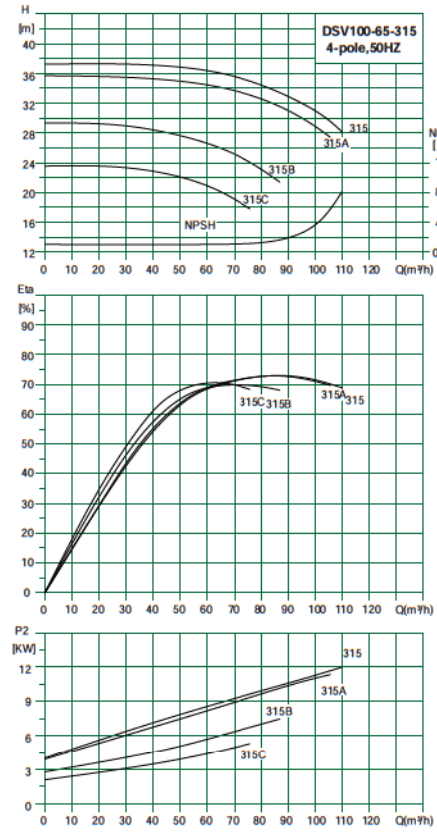

Performance Curve

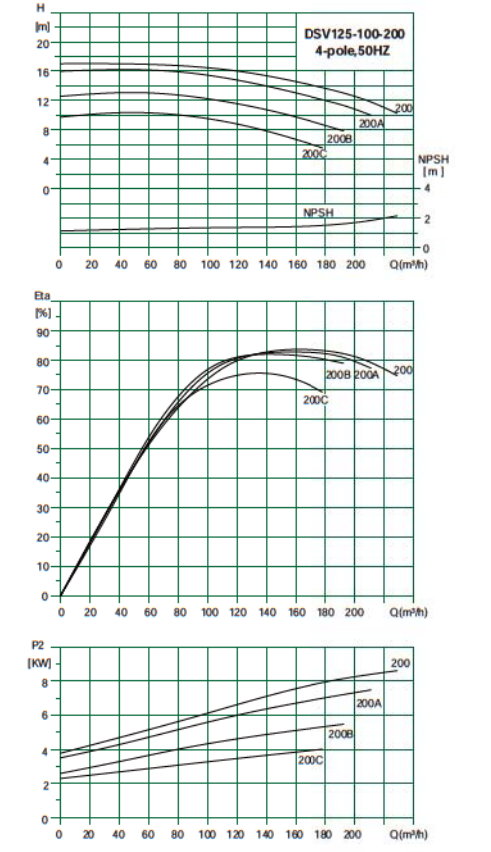
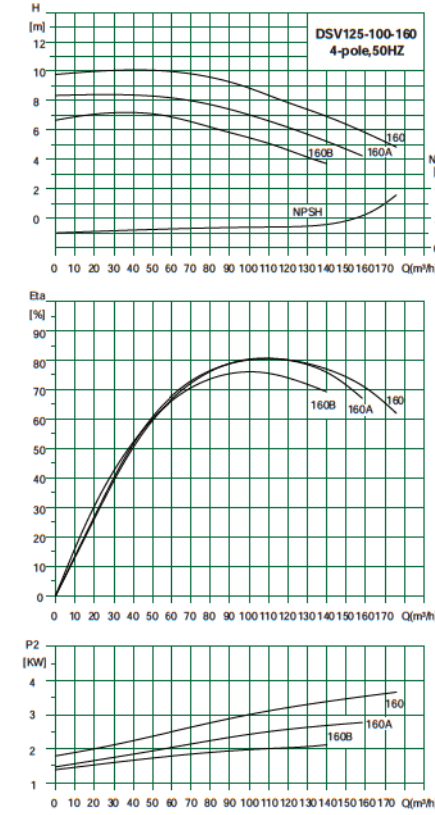
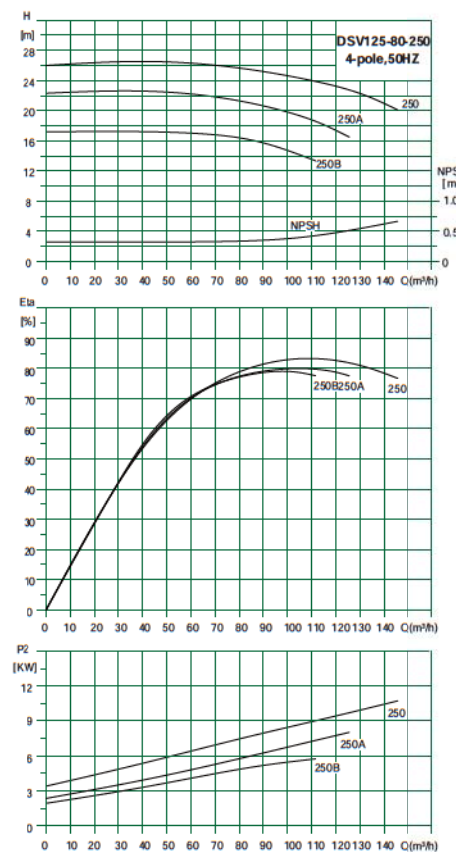
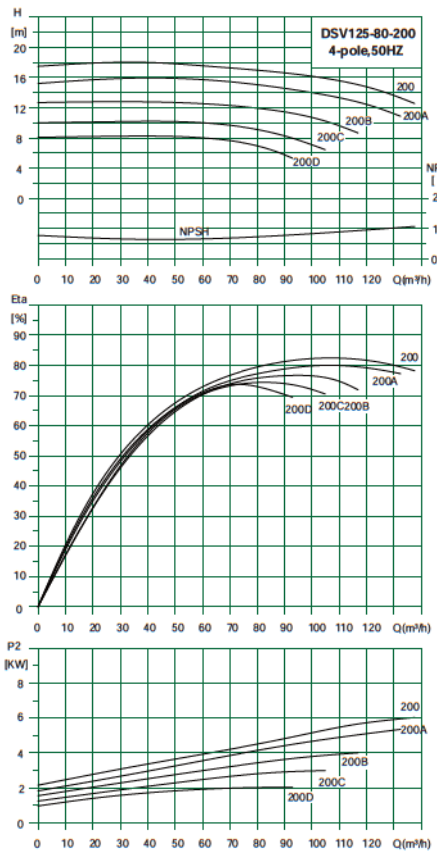
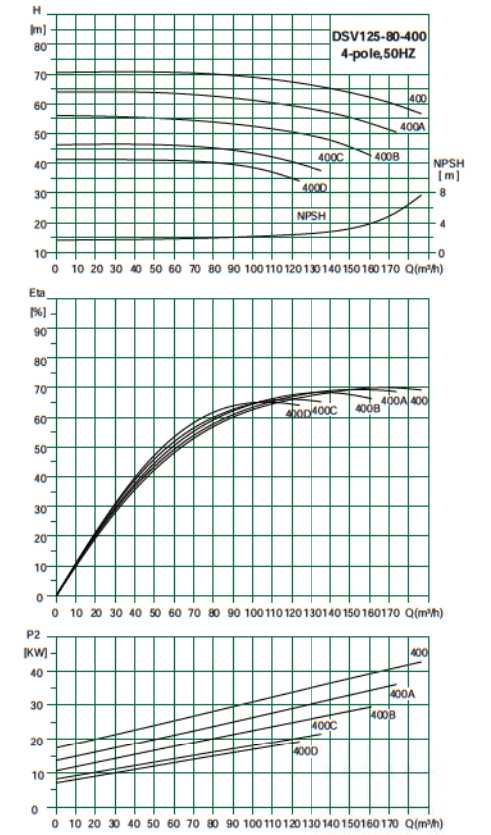
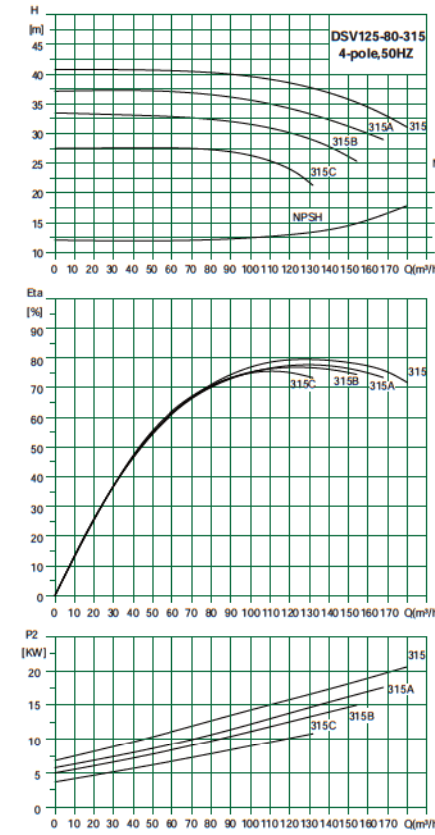

Performance Curve

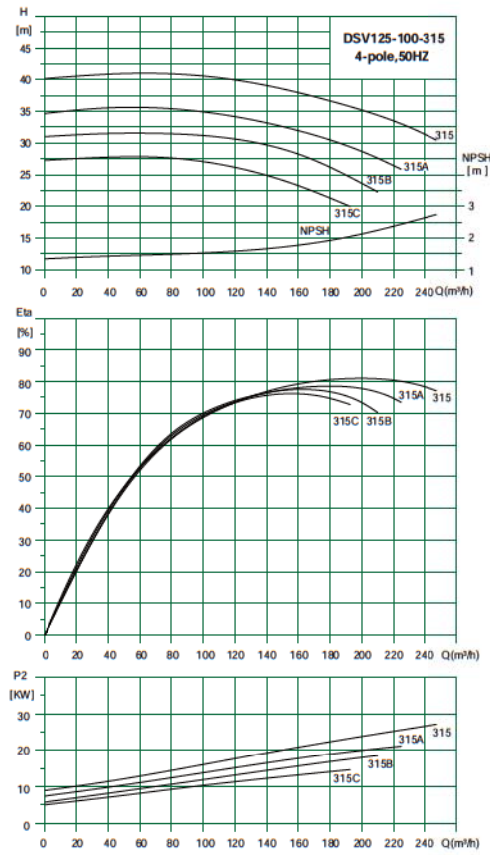
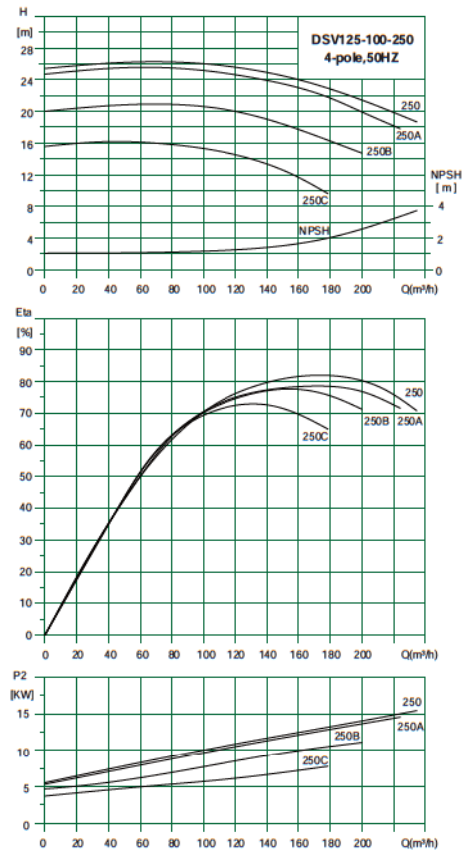

Performance Curve

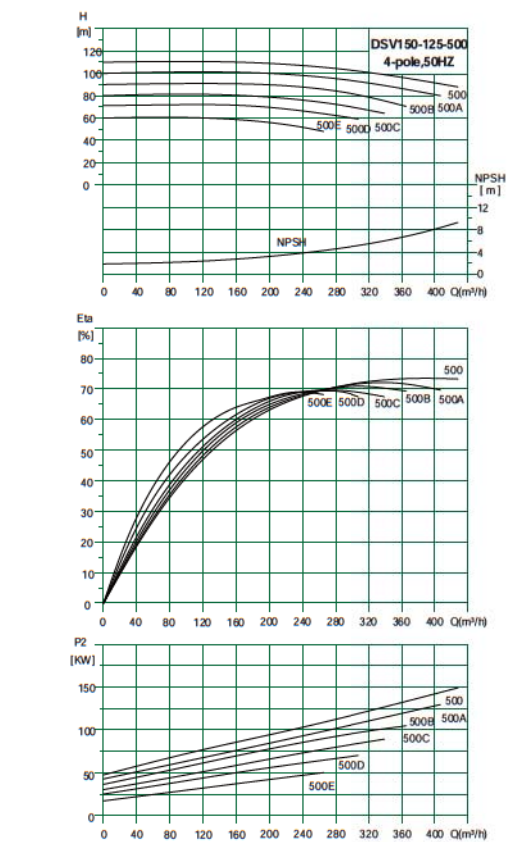
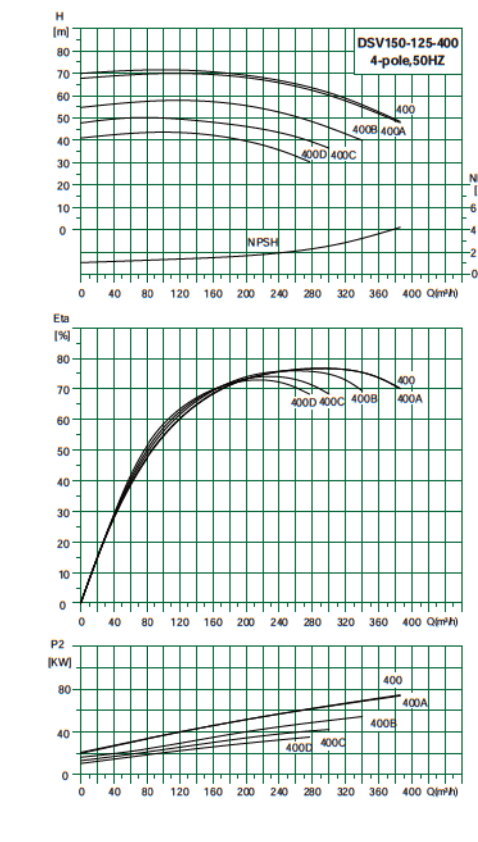
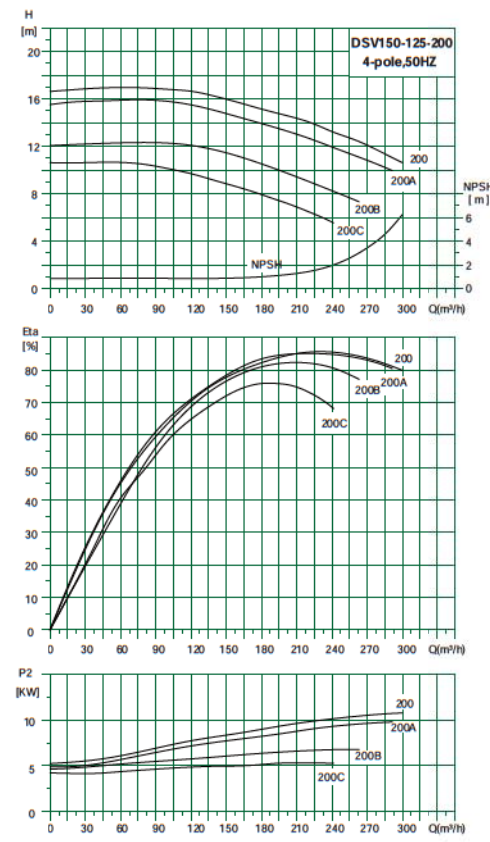
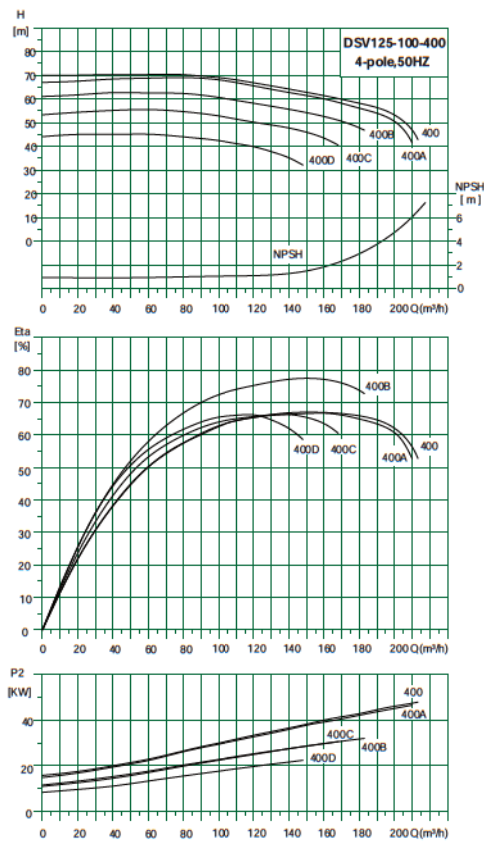
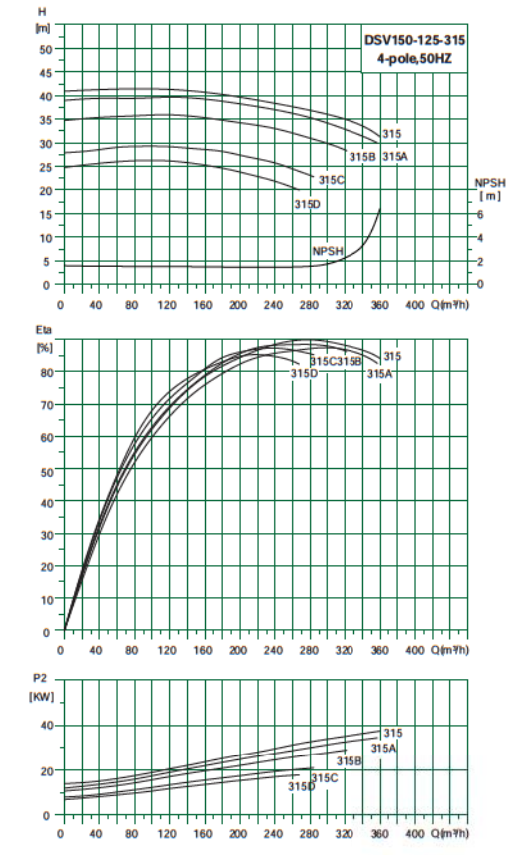
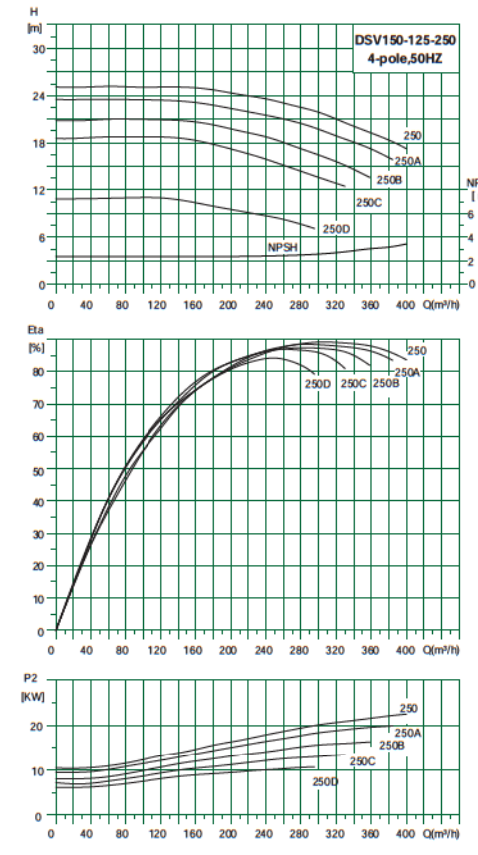

Performance Curve

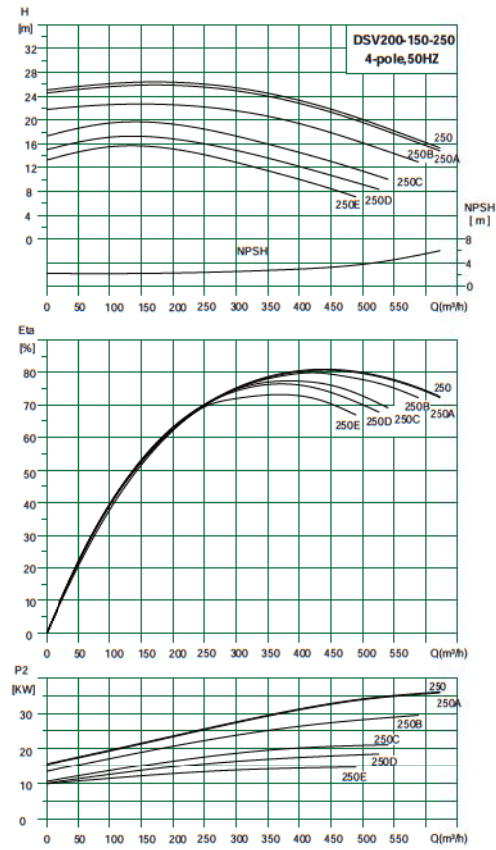
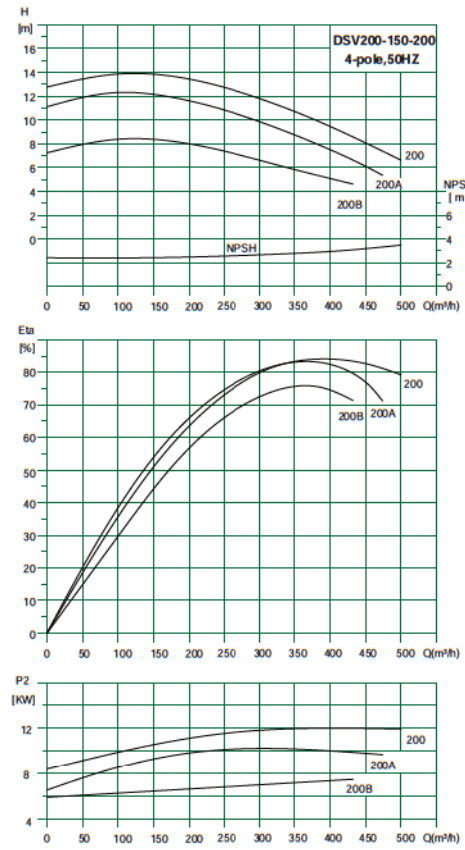

Performance Curve

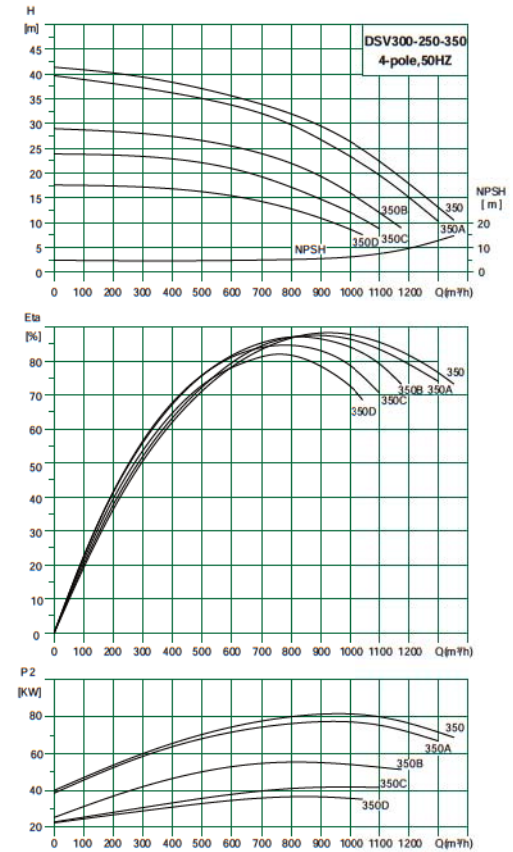
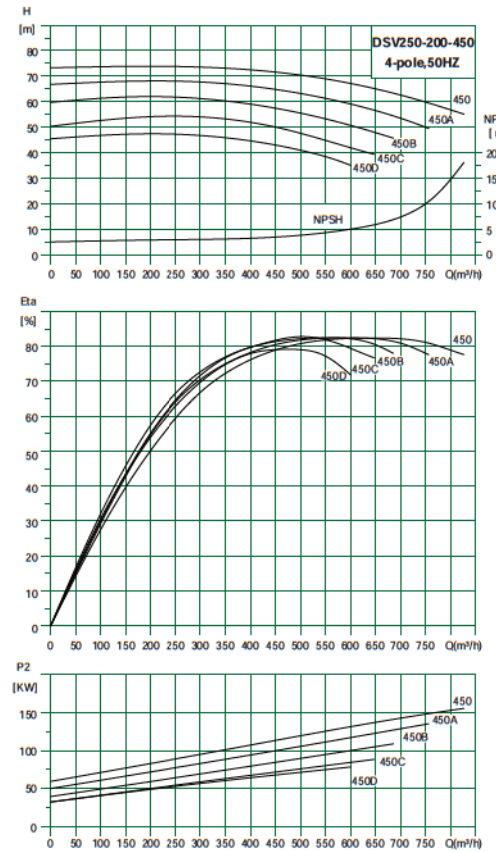
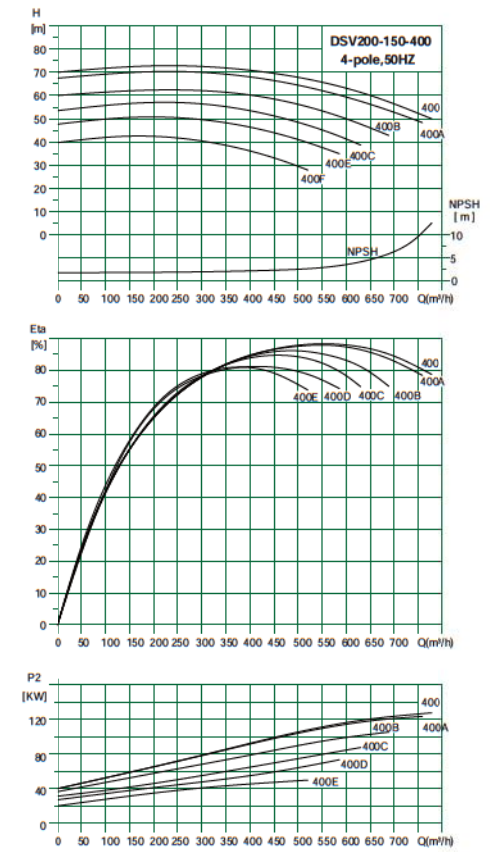
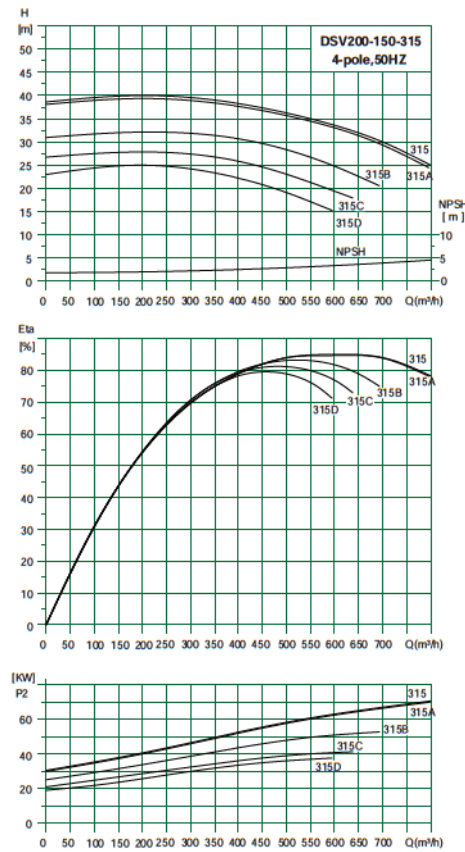
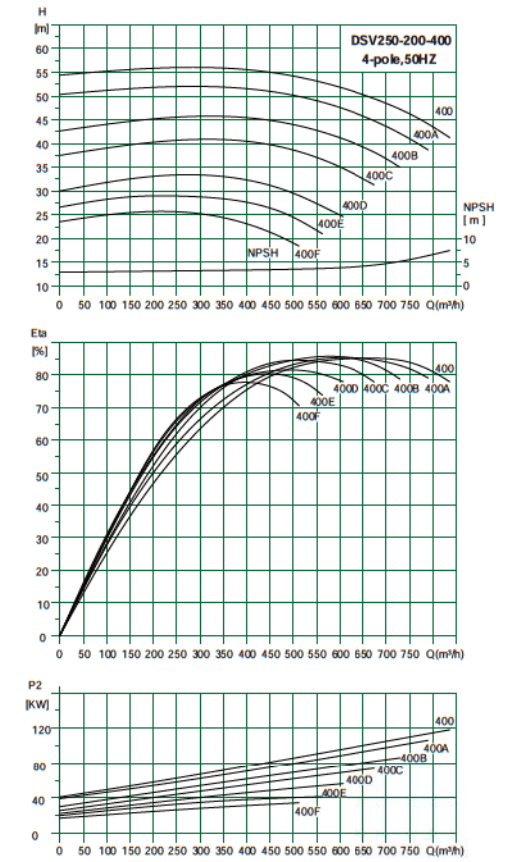
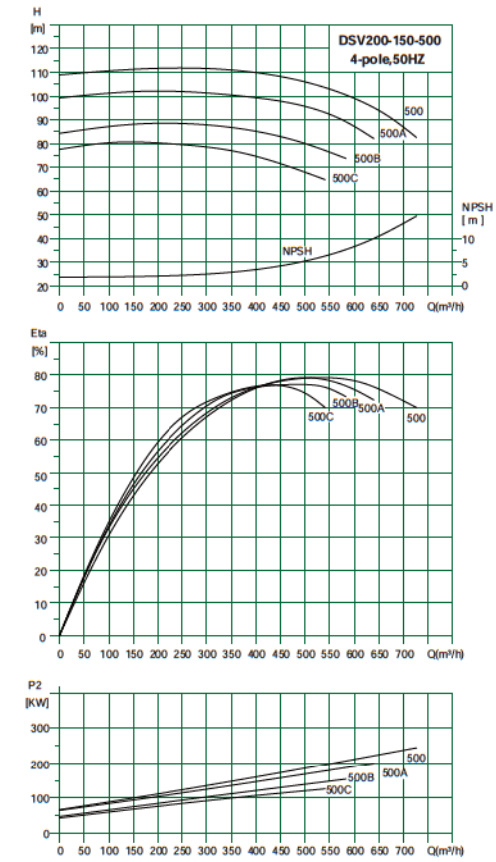

Performance Curve

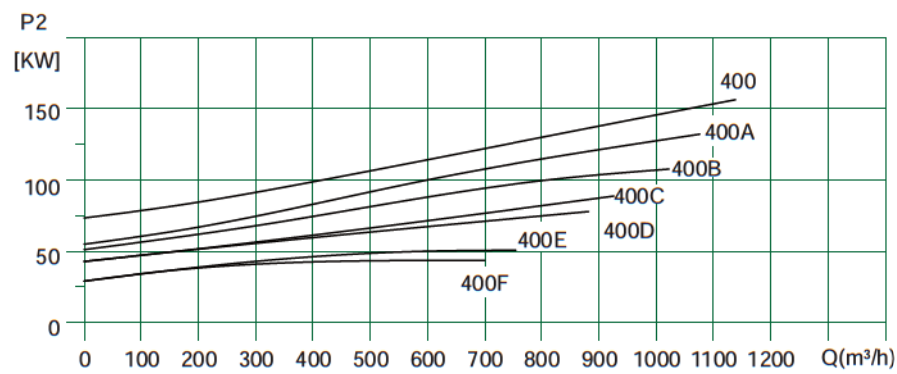
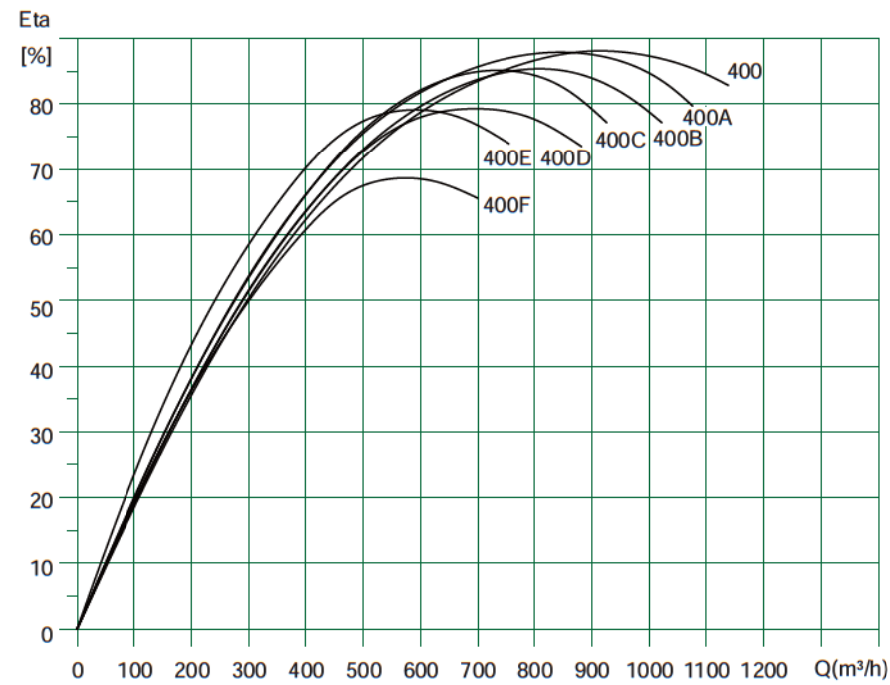
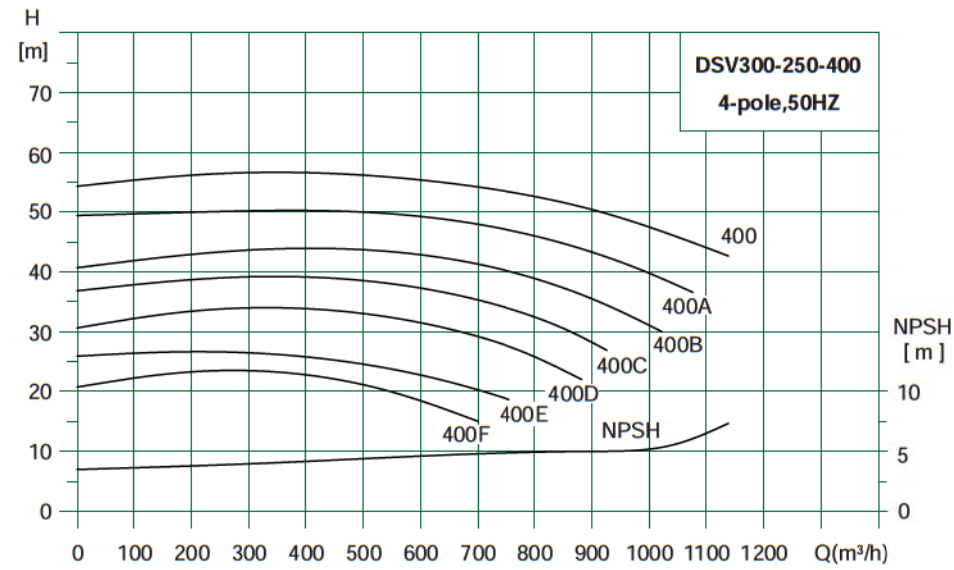

Performance Curve

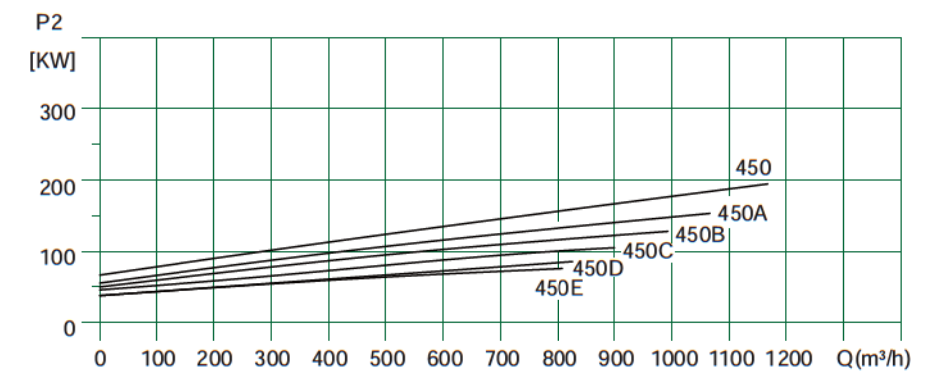
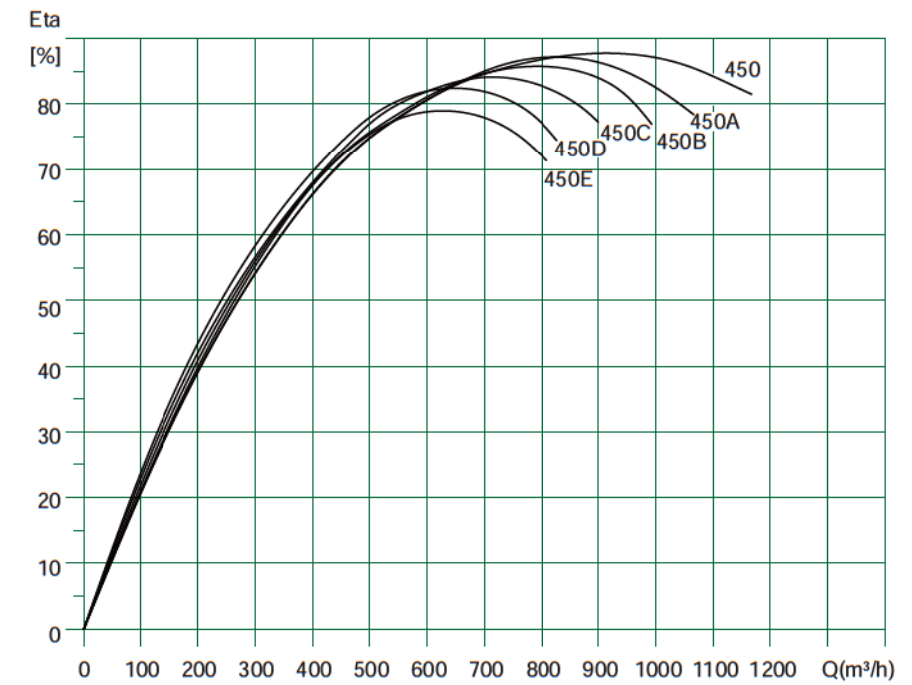
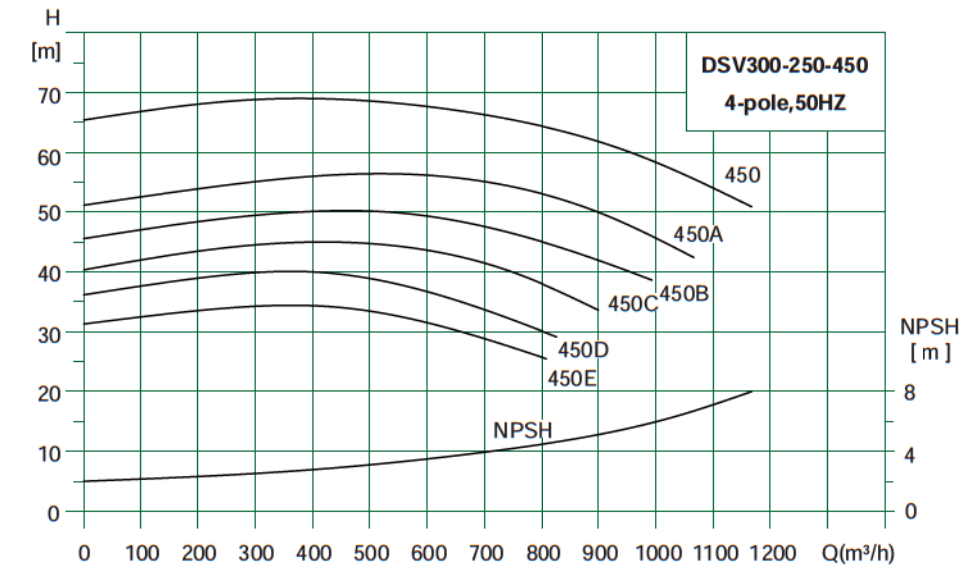

Performance Curve

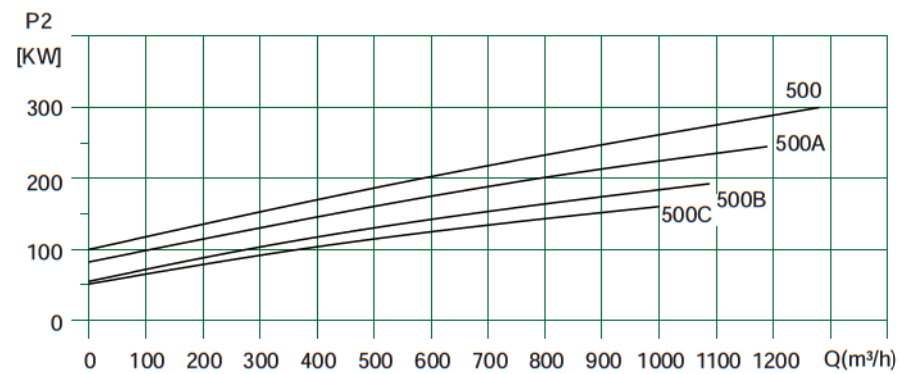
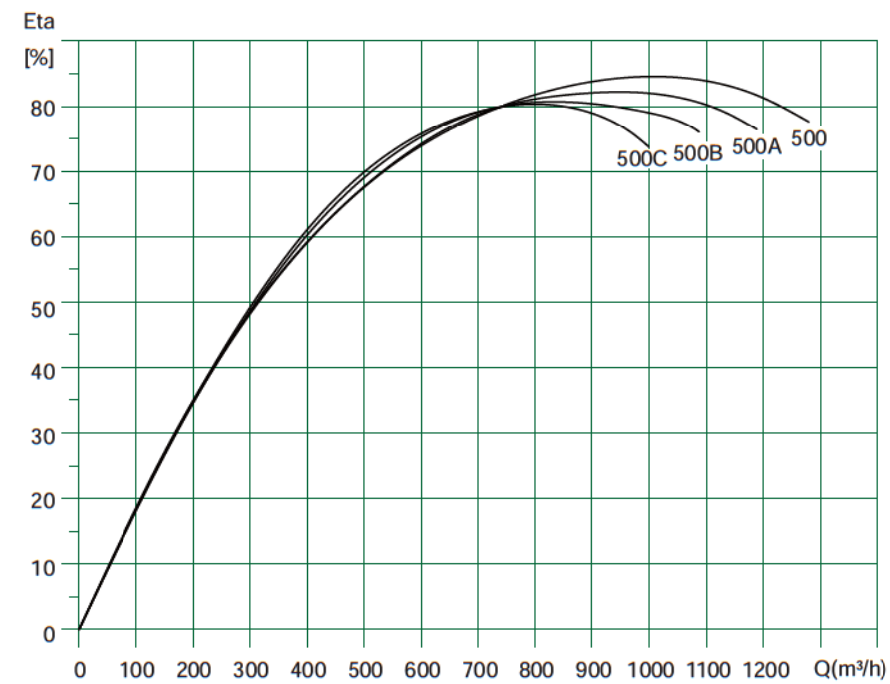
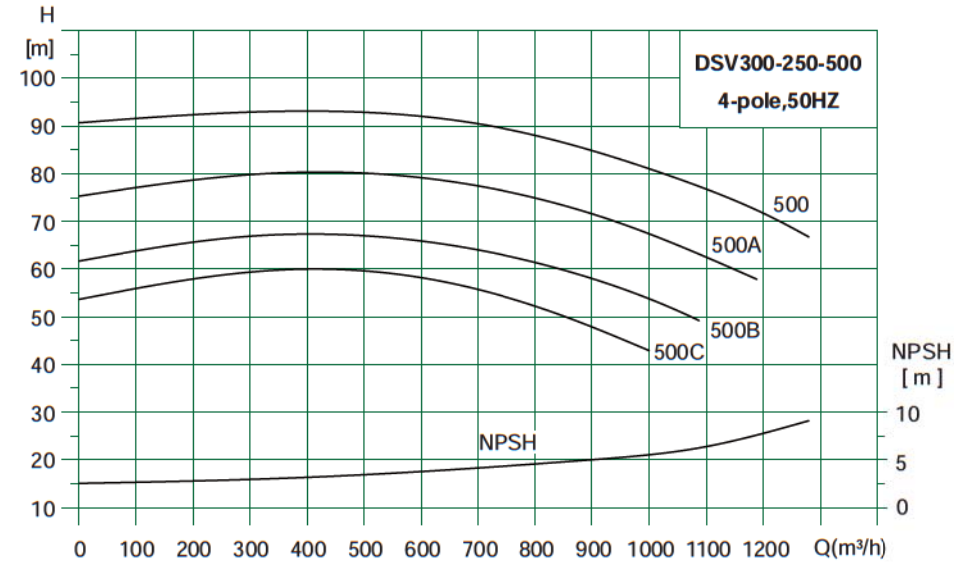

Pump Head Size Center Line Outlet

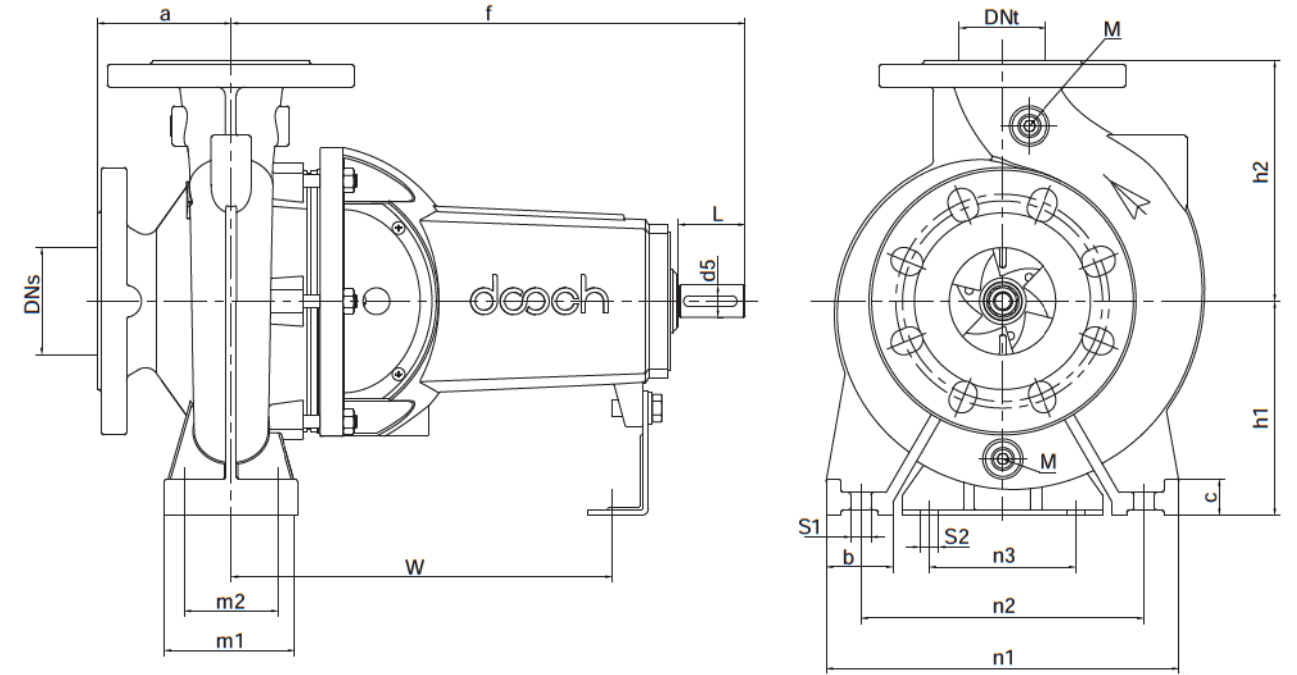

Model	DNs	DNt	a	f	h1	h2	M	b	m1	m2	n1	n2	n3	w	S1	S2	c	d5	L	Weight (kg)
DSV50-32-125	50	32	80	385	112	140	3/8	50	100	70	190	140	110	285	M12	M12	27	24	50	44
DSV50-32-160	50	32	80	385	132	160	3/8	50	100	70	240	190	110	285	M12	M12	27	24	50	46
DSV50-32-200	50	32	80	385	160	180	3/8	50	100	70	240	190	110	285	M12	M12	27	24	50	54
DSV50-32-250	50	32	100	500	180	225	3/8	65	125	95	320	250	110	370	M12	M12	28	32	80	83
DSV65-50-125	65	50	80	385	112	140	3/8	50	100	70	210	160	110	285	M12	M12	27	24	50	47
DSV65-50-160	65	50	80	385	132	160	3/8	50	100	70	240	190	110	285	M12	M12	27	24	50	48
DSV65-40-200	65	40	100	385	160	180	3/8	50	100	70	265	212	110	285	M12	M12	27	24	50	55
DSV65-40-250	65	40	100	500	180	225	3/8	65	125	95	320	250	110	370	M12	M12	28	32	80	81
DSV65-40-315	65	40	125	500	200	250	3/8	65	125	95	345	280	110	370	M12	M12	28	32	80	124
DSV80-65-125	80	65	100	385	132	160	3/8	50	100	70	240	190	110	285	M12	M12	27	24	50	50
DSV80-65-160	80	65	100	385	160	180	3/8	50	100	70	265	212	110	285	M12	M12	27	24	50	52
DSV80-50-200	80	50	100	385	160	200	3/8	50	100	70	265	212	110	285	M12	M12	27	24	50	58
DSV80-50-250	80	50	125	500	180	225	3/8	65	125	95	320	250	110	370	M12	M12	28	32	80	86
DSV80-50-315	80	50	125	500	225	280	1/2	65	125	95	345	280	110	370	M12	M12	28	32	80	130

Pump Head Size Center Line Outlet

Model	DN _s	DN _t	a	f	h ₁	h ₂	M	b	m ₁	m ₂	n ₁	n ₂	n ₃	w	S1	S2	c	d ₅	L	Weight (kg)
DSV100-80-125	100	80	100	385	160	180	3/8	65	125	95	280	212	110	285	M12	M12	28	24	50	55
DSV100-80-160	100	80	100	385	160	200	3/8	65	125	95	280	212	110	285	M12	M12	28	24	50	72
DSV100-65-200	100	65	100	500	180	225	3/8	65	125	95	320	250	110	370	M12	M12	28	24	50	81
DSV100-65-250	100	65	125	500	200	250	1/2	80	160	120	360	280	110	370	M16	M12	35	32	80	111
DSV100-65-315	100	65	125	530	225	280	3/8	80	160	120	400	315	110	370	M16	M12	35	42	110	141
DSV125-80-160	125	80	125	500	180	225	3/8	65	125	95	320	250	110	370	M12	M12	27	32	80	81
DSV125-80-200	125	80	125	500	180	250	3/8	65	125	95	345	280	110	370	M12	M12	27	32	80	95
DSV125-80-250	125	80	125	500	225	280	3/8	80	160	120	400	315	110	370	M16	M12	35	32	80	115
DSV125-80-315	125	80	125	530	250	315	3/8	80	160	120	400	315	110	370	M16	M12	30	42	110	152
DSV125-80-400	125	80	125	530	280	355	1/2	80	160	120	435	355	110	370	M16	M12	35	42	110	270
DSV125-100-160	125	100	125	500	200	280	3/8	80	160	120	360	280	110	370	M16	M12	35	32	80	99
DSV125-100-200	125	100	125	500	200	280	1/2	80	160	120	360	280	110	370	M16	M12	35	32	80	107
DSV125-100-250	125	100	140	530	225	280	1/2	80	160	120	400	315	110	370	M16	M12	35	42	110	133
DSV125-100-315	125	100	140	530	250	315	1/2	80	160	120	400	315	110	370	M16	M12	35	42	110	161
DSV125-100-400	125	100	140	530	280	355	1/2	100	200	150	500	400	110	370	M20	M12	35	42	110	242
DSV150-125-200	150	125	140	500	250	315	1/2	80	160	120	400	315	110	370	M16	M12	23	32	80	135
DSV150-125-250	150	125	140	530	250	355	1/2	80	160	120	400	315	110	370	M16	M12	23	42	110	158
DSV150-125-315	150	125	140	530	280	355	1/2	100	200	150	500	400	110	370	M16	M12	35	42	110	190
DSV150-125-400	150	125	140	530	315	400	1/2	100	200	150	500	400	110	370	M16	M12	35	42	110	254
DSV150-125-500	150	125	180	670	400	500	1/2	125	200	150	625	500	140	500	M20	M16	45	60	110	503
DSV200-150-200	200	150	160	500	280	400	1/2	100	200	150	550	450	110	370	M20	M12	30	32	80	190
DSV200-150-250	200	150	160	530	280	375	1/2	100	200	150	500	400	110	370	M20	M12	30	42	110	195
DSV200-150-315	200	150	160	670	315	400	1/2	100	200	150	550	450	140	500	M20	M16	30	48	110	326
DSV200-150-400	200	150	160	670	315	400	1/2	100	200	150	550	450	140	500	M20	M16	45	48	110	366
DSV200-150-500	200	150	180	670	400	500	1/2	125	200	150	625	500	140	500	M20	M16	45	60	110	523

Pump Head Size Cross Section Outlet

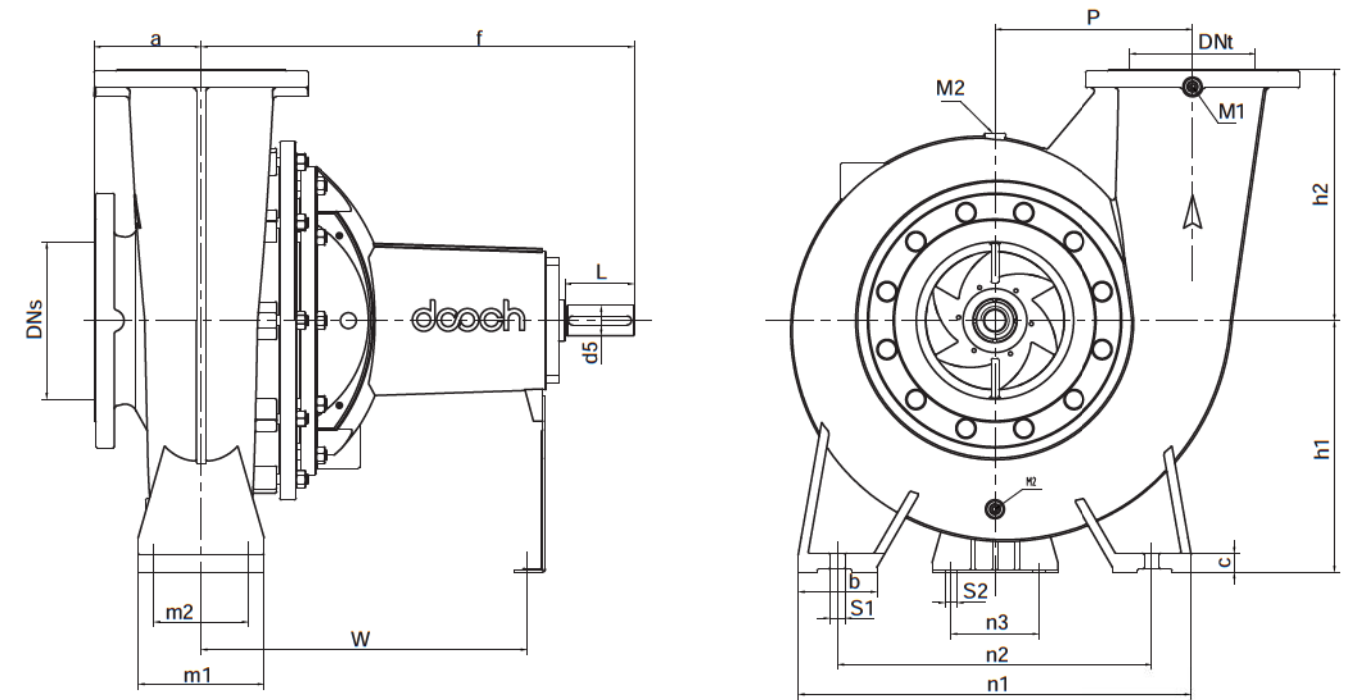

Model	DN _s	DN _t	a	f	h ₁	h ₂	M	M2	p	b	m ₁	m ₂	n ₁	n ₂	n ₃	w	S1	S2	c	d ₅	L	Weight (kg)
DSV250-200-400	250	200	170	689	400	400	1/2	3/8	315	125	200	150	625	500	140	519	M20	M16	30	48	110	428
DSV250-200-450	250	200	150	689	400	450	1/2	3/8	355	125	200	150	625	500	140	519	M20	M16	30	48	110	443
DSV300-250-350	300	250	175	729	450	400	1/2	3/8	320	125	200	150	625	500	140	559	M20	M16	30	48	110	528
DSV300-250-400	300	250	160	702	450	500	1/2	3/8	295	125	200	150	625	500	140	532	M20	M16	30	48	110	479
DSV300-250-450	300	250	165	685	450	500	1/2	3/8	360	125	200	150	625	500	140	515	M20	M16	30	60	110	557
DSV300-250-500	300	250	165	693	450	500	1/2	3/8	395	125	200	150	725	600	140	523	M20	M16	30	60	110	670

Flange Specification

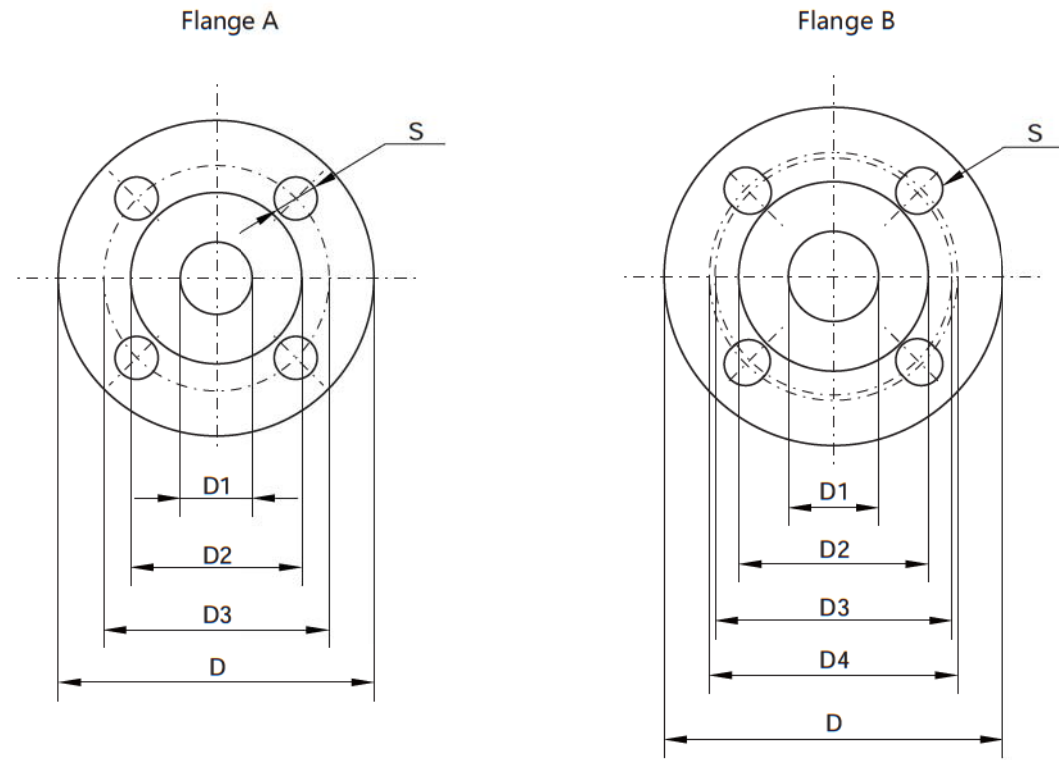

Caliber	D1	D2	D3	D4	D	S	Type
DN32	32	76	100	/	140	4-Φ19	Flange A
DN40	40	84	105	110	150	4-19x21.5	Flange B
DN50	50	99	120	125	165	8-19x21.5	Flange B
DN65	65	118	140	145	185	8-19x21.5	Flange B
DN80	80	132	150	160	200	8-19x24	Flange B
DN100	100	156	175	180	220	8-19x21.5	Flange B
DN125	125	184	210	/	250	8-Φ19	Flange A
DN150	150	211	240	/	285	8-Φ23	Flange A
DN200	200	266	290	295	340	12-23x25.5	Flange B
DN250	250	319	355	/	405	12-Φ28	Flange A
DN300	300	370	400	410	460	12-28x33	Flange B